

SUG series 2/2 Solenoid Valve

Product features/ Code of order

CHELIC

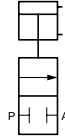

Code of order

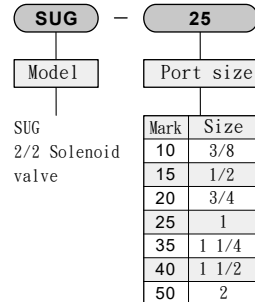

Specification

Item	Model	SUG-10	SUG-15	SUG-20	SUG-25	SUG-35	SUG-40	SUG-50
Fluid		Applicable to air, water and oil						
Ambient and fluid temperature °C		-5 ~ 100						
Pilot type		Direct operated						
Applicable medium viscosity		50 CST or below						
Bore size (mm)		20	20	20	32	50	50	63
Port size		PT 3/8	PT 1/2	PT 3/4	PT 1	G 1 1/4	G 1 1/2	G 2
Orifice (mm)		16	16	20	25	35	40	50
Cv factor		4.8	4.8	12	7.6	24	29	48
Pressure range (kgf/cm ² /kPa)		0 ~ 7 (0 ~ 700)						
Withstand pressure (kgf/cm ² /kPa)		10.5 (1050)						
Control pressure range (kgf/cm ² /kPa)		3 ~ 6 (300~600)						
Material	Body	Brass						
	Grease seal	PTFE						
Main port size		2-M5 x 0.8P			2-G 1/8	2-G 1/4	2-G 1/4	2-G 1/4

Note: The product is not applicable to certain fluid such as in high temperature as liquid but being solid after cooling, or the corrosive liquid that viscosity over 20 CST.

External dimensions

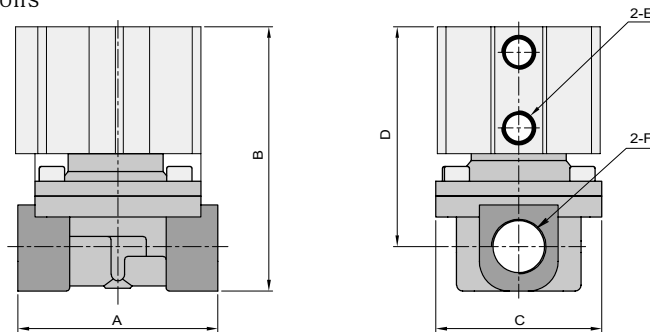

Model	A	B	C	D	E	F
SUG-10	66	84	57.5	72	M5 x 0.8P	PT 3/8
SUG-15	66	89	57.5	77	M5 x 0.8P	PT 1/2
SUG-20	70	94	57.5	79.5	M5 x 0.8P	PT 3/4
SUG-25	92	108	77	87.5	G 1/8	PT 1
SUG-35	120	125	88	100.5	G 1/4	G 1 1/4
SUG-40	125	130	93	102.5	G 1/4	G 1 1/2
SUG-50	168	152	120	117	G 1/4	G 2