

2/2 Pilot Operated Valve

CHELIC®



SCQ series

Applicable

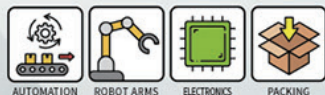

SCQ 20

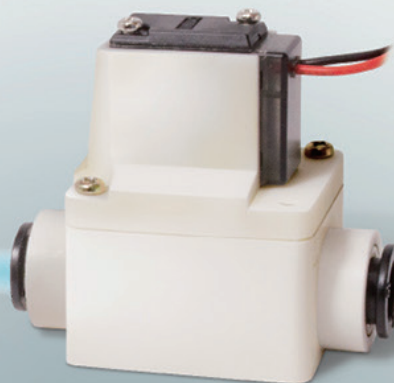

SCQ 30

Highly efficient blower-type

160% capacity

◎ Guiding coil design, minimizing the size.

◎ Plastic main body makes it much lighter.

A **41%** decrease in size compared to the old model



A **34%** decrease in weight compared to the old model



Low power consumption coil (**0.6W**) achieving great capacity with outstanding power efficiency.

Lighter and more compact

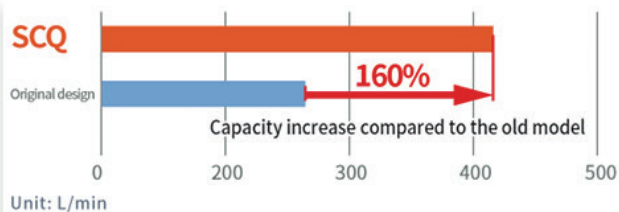

Application method

Large capacity cleaning air blowing



Supply and emission of oxygen concentrator, etc.

Application example



Machine tool

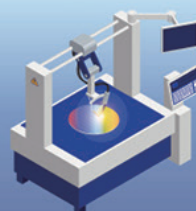

Semiconductor



Medicine

SCQ series 2/2 Pilot Operated Valve

Product features/ Code of order

CHELIC

Feature

- Low power.
- Compact with large flow capacity.
- Weight reduction 23%
(compare with SU series)

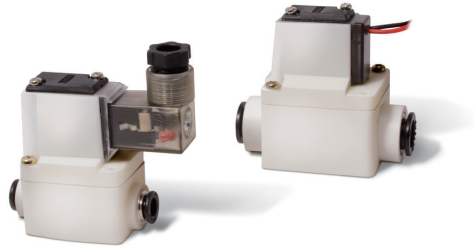

Specification

Item	Model	C8, C10	C10, C12
Fluid		Air	
The max. operating pressure differential	kgf / cm ² (kPa)	6 (600)	5 (500)
Min. operating pressure differential	kgf / cm ² (kPa)	0.1 (10) <small>Note: 3</small>	
Ambient and fluid temperature	°C	0 ~ 50 (Prevent freeze)	
Pilot type		Air operated	
Number of positions		2/2-position	
Type of actuation		Poppet pilot operated / Normally closed	
Effective orifice	cv	0.39 (Ø8)	0.81 (Ø12)
Port size		Ø6, Ø8	Ø10, Ø12
Working environment		Prevent from corrosive gas, explosive gas, or a water place.	
Lubrication		NO	
Voltage		DC 24V	
Weight	g	70	99

Note: 1. This product is for dry air. Use in clean air, and be sure that drain and oil content does not flow into the product.

2. Use dry air to prevent condensation when operating at low temperatures.

3. If a restrictor (nozzle, etc.) is mounted on the outlet side piping, the pressure differential when ON is smaller. Be sure that the pressure differential does not drop below 0.01 MPa.

Code of order **SCQ 20 - C6 - D2 - K**

1 — 2 — 3 — 4

1	Mark	Model
	20	2 series
	30	3 series

2	Fitting port		
	Mark	Port size	Model
	C6	Ø6	SCQ 20
	C8	Ø8	
	C10	Ø10	SCQ 30
	C12	Ø12	

3	Mark	Voltage
	D2	24 V DC / 0.6W

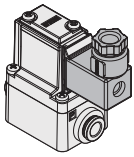
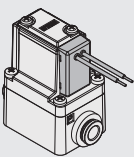
4	Electrical entry	
		
	K: DIN Terminal	W: Grommet

● W: With wire length 300mm

SCQ series 2/2 Pilot Operated Valve

Product features

CHELIC

Internal structure

2 port 2-position single

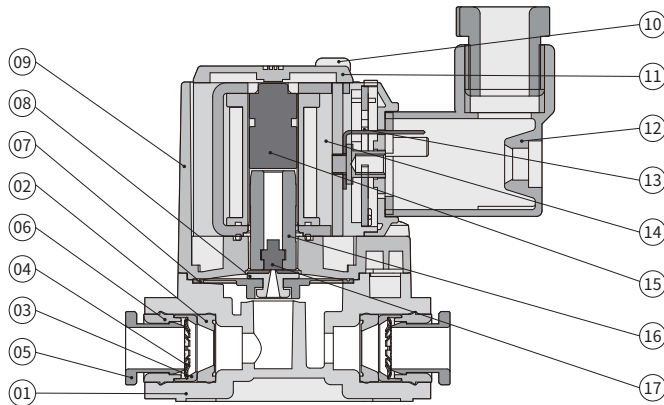
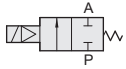

Components and material list

No.	Item	Material	No.	Item	Material
01	Body	PBT	10	Screw	Iron
02	Fitting gasket	NBR	11	Coil cover	PBT
03	Chuck base	Copper alloy	12	Light box	Plastic
04	Chuck	SUS	13	PCB combination	Fiberglass
05	Release button	POM	14	Coil	PBT + Copper
06	Mid-button base	CU	15	Coil insert bushing	SUS
07	Diaphragm type	NBR	16	Spring bushing	SUS
08	Valve mouth	POM	17	Valve port rubber ring	NBR
09	Top cover	PBT			

SCQ series 2/2 Pilot Operated Valve

Dimensions

CHELIC

■ SCQ20-C6-W

SCQ20-C8-W

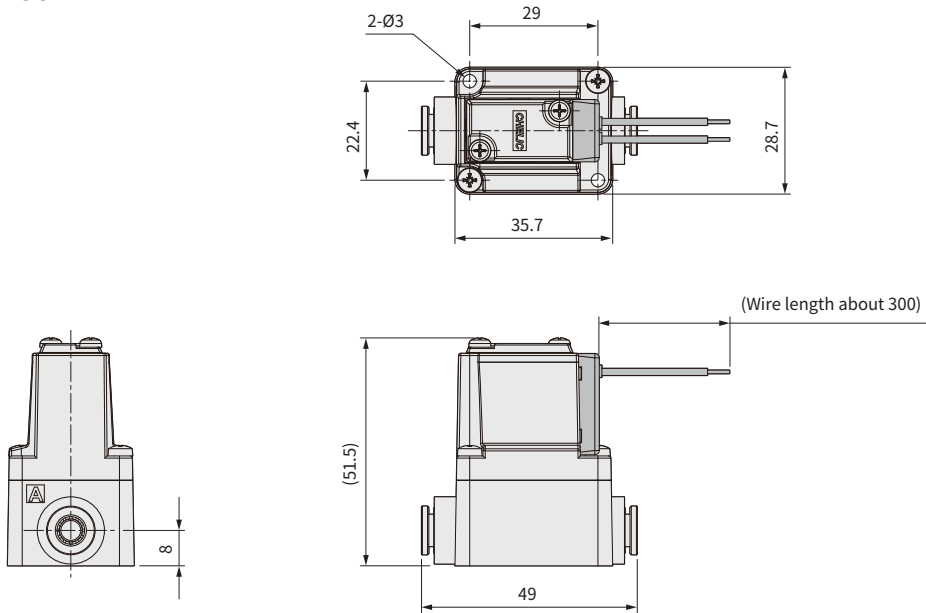

■ SCQ20-C6-K

SCQ20-C8-K

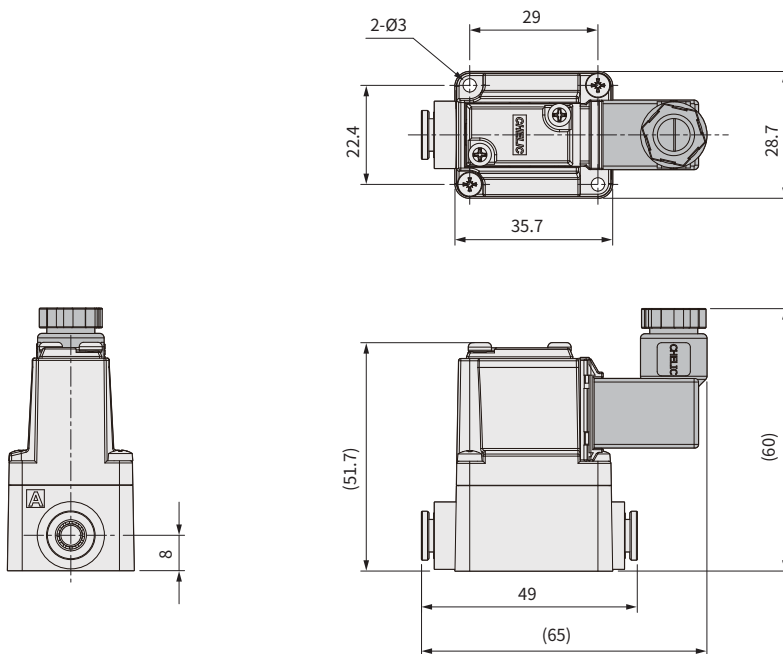

SCQ series 2/2 Pilot Operated Valve

Dimensions

CHELIC

- SCQ30 - C10 - W
- SCQ30 - C12 - W

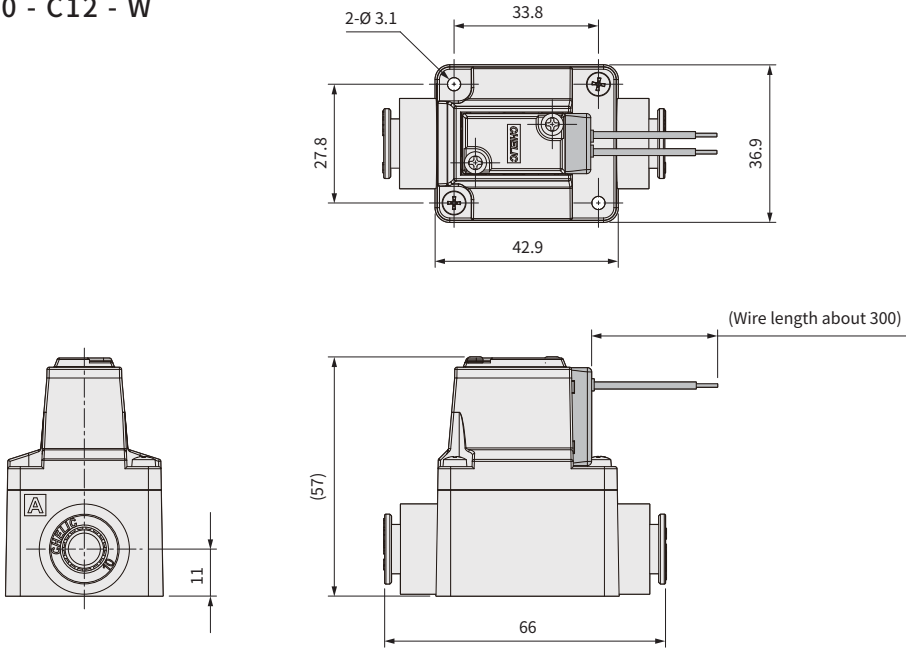

- SCQ30 - C10 - K
- SCQ30 - C12 - K

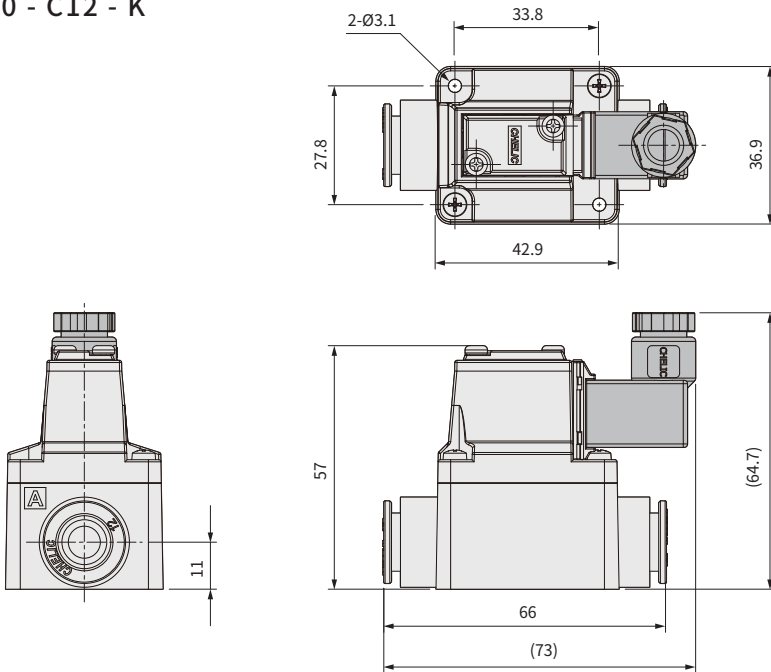



Safety Notice/ SCQ/ Caution For Application

CHELIC

- Please read this safety notice carefully, pay attention to safety item while using this product, in order to prevent injury to human body and damage of property.
- Pay attention to the individual caution for various model series (read the cautions and safety notice in P. 2 ~ P.3 for common cautions and safety notice).

Caution for design, selection



WARNING

- This product is for dry air. Drain, oil, etc. in the air may result in faulty operation. Use clean (dry) air.
- If a restrictor (nozzle, etc.) is mounted on the outlet side, the outlet side pressure differential at the inlet side is smaller. Be sure the pressure differential when ON does not drop below 0.01 MPa.

Valve Mounting



CAUTION

- When mounting the valve, secure with brackets. When mounting it directly, tighten the mounting screws with the appropriate torque (0.7 to 0.8N·m).

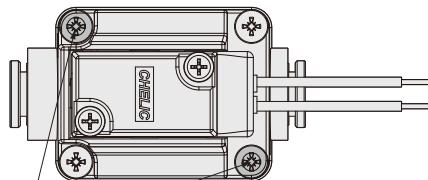

Tightening torque
0.7 ~ 0.8N·m

Mounting screw

- Power wave form of power-saving type (Rated voltage at 24 VDC)

