

QS □ series Speed Controller

Product features/ Code of order

CHELIC

Internal structure

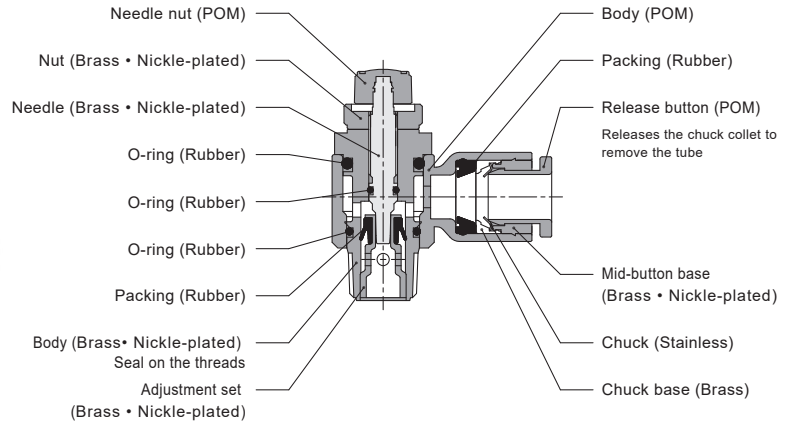

Specification

Item	Port size	Ø4, Ø6, Ø8, Ø10, Ø12, 5/32", 1/4", 5/16", 3/8", 1/2"
Fluid		Air
Pressure range	kgf/cm ² (kPa)	0 ~ 9 (0 ~ 900)
Proof pressure	kgf/cm ² (kPa)	10 (1000)
Number of needle rotation		10 (8) round
Ambient and fluid temperature	°C	(0 ~ 60)
Material	Body	Brass (Nickel-plated)
	Plastic	NYLON, PBT, PP
Thread	Rc (PT/NPT)	M3x0.5p, M5x0.8p (10/32"), 1/8", 1/4", 3/8", 1/2"
Seal on the threads		With sealant

Code of order

QSC - 6 - 01 - A

Model - Port size - Thread - Control direction

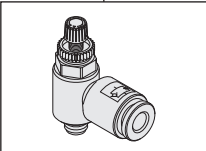

QSC: Speed Controller

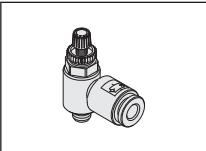

QSM:
Speed Controller - Mini Type

Metric

4 - Ø 4 mm
6 - Ø 6 mm
8 - Ø 8 mm
10 - Ø 10 mm
12 - Ø 12 mm

Inch

5/32" - Ø 3.97 mm
1/4" - Ø 6.35 mm
5/16" - Ø 7.94 mm
3/8" - Ø 9.53 mm
1/2" - Ø 12.7 mm

Metric

M3 - M3x0.5p
M5 - M5x0.8p
01 - PT 1/8"
02 - PT 1/4"
03 - PT 3/8"
04 - PT 1/2"

Inch

10/32" - NR 10/32"
01 - NPT 1/8"
02 - NPT 1/4"
03 - NPT 3/8"
04 - NPT 1/2"

M3 is the specific item for QSM.

QSC 601A

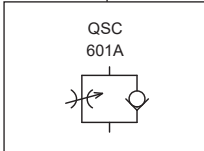

A): Meter-out controller

QSC 601B

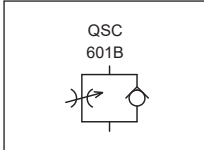

B): Meter-in controller

QS series Speed Controller

Product features

CHELIC

Specification

● Metric

Unit: mm

Model	Port size	Thread size (PT)				
		M5	1/8"	1/4"	3/8"	1/2"
QSC 4 - <input type="checkbox"/>	Ø4	●	●	●		
QSC 6 - <input type="checkbox"/>	Ø6	●	●	●	●	
QSC 8 - <input type="checkbox"/>	Ø8		●	●	●	
QSC 10 - <input type="checkbox"/>	Ø10			●	●	●
QSC 12 - <input type="checkbox"/>	Ø12				●	●

● Imperial

Unit: Inch

Model	Port size	Thread size (NR / NPT)				
		10/32"	1/8"	1/4"	3/8"	1/2"
QSC 5/32" - <input type="checkbox"/>	5/32"	●	●	●		
QSC 1/4" - <input type="checkbox"/>	1/4"	●	●	●	●	
QSC 5/16" - <input type="checkbox"/>	5/16"		●	●	●	
QSC 3/8" - <input type="checkbox"/>	3/8"			●	●	●
QSC 1/2" - <input type="checkbox"/>	1/2"				●	●

Control direction for speed controller

- A Meter-out controller(standard)

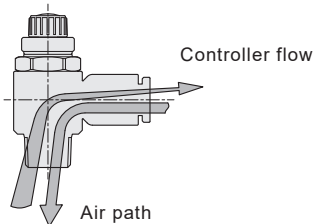

- B Meter-in controller

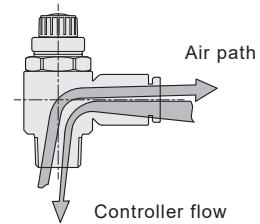

Flow rate characteristic graph

● QSC 4 - M5

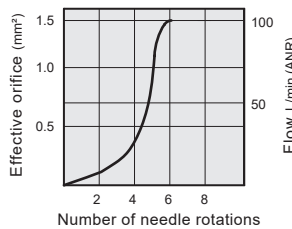

● QSC 6 - 01

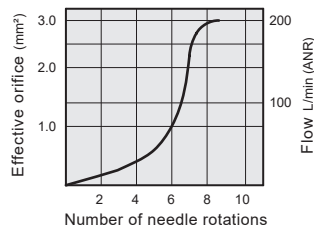

● QSC 8 - 02

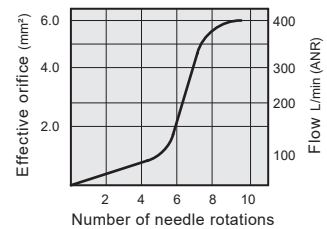

● QSC 10 - 03

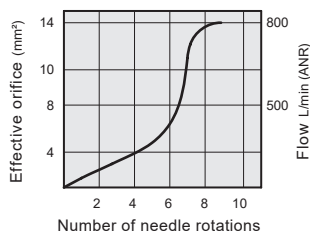

● QSC 12 - 04

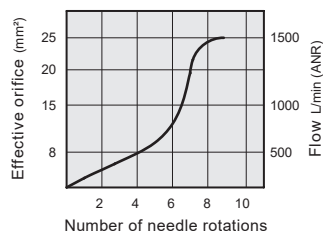

QS

MSQ

SP

SQ J

SQR

SQ G

RQL

M

Stainless steel fitting

Brass Fitting

Full copper fitting

SC

QS

QMC

QT

QH

QV

QST

PU Tube

QSC series Speed Controller

Dimensions

CHELIC

QSC series Speed controller

Metric specification



Port size ØD	Thread size Rc (PT)	Model	A	B		C	E	L		ØG1	ØG2	Across flats H	Effective orifice mm ²	Weight (g)
				max	min			max	min					
Ø4	M5	QSC 4 - M5	3.8	27.8	24.8	14.8	19.9	29.7	26.7	10.5	10	8	4	10
	1/8"	QSC 4 - 01	6	35.4	31.6	14.6	21.6	38.4	34.6	10.5	14.2	12	5.5	20
	1/4"	QSC 4 - 02	9	37	33.4	14.6	21.6	41.5	37.9	10.5	18.6	17	12.5	34
Ø6	M5	QSC 6 - M5	3.8	27.8	24.8	17.1	21.8	29.7	26.7	12.4	10	8	4	10
	1/8"	QSC 6 - 01	6	35.4	31.6	17.1	23.7	38.4	34.6	12.4	14.2	12	5.5	20
	1/4"	QSC 6 - 02	9	37	33.4	17.1	25.9	41.5	37.9	12.4	18.6	17	12.5	36
Ø8	3/8"	QSC 6 - 03	10	45.3	40.2	17.1	28	50.3	45.2	12.4	23	19	20	60
	1/8"	QSC 8 - 01	6	35.4	31.6	18.9	25.5	38.4	34.6	14.3	14.2	12	5.5	20
	1/4"	QSC 8 - 02	9	37	33.4	18.9	27.7	41.5	37.9	14.3	18.6	17	12.5	36
Ø10	3/8"	QSC 8 - 03	10	45.3	40.2	18.9	29.9	50.3	45.2	14.3	23	19	20	60
	1/4"	QSC 10 - 02	9	37	33.4	20.4	29.6	41.5	37.9	17.8	18.6	17	12.5	40
	3/8"	QSC 10 - 03	10	45.3	40.2	20.4	31.7	50.3	45.2	17.8	23	19	20	64
Ø12	1/2"	QSC 10 - 04	14	55	46.6	20.3	34.6	62	53.6	17.8	28.8	24	35	98
	3/8"	QSC 12 - 03	10	45.3	40.2	22.8	35	50.3	45.2	21.5	21.2	19	20	68
	1/2"	QSC 12 - 04	14	55	46.6	22.8	37.2	62	53.6	21.5	28.8	24	35	102

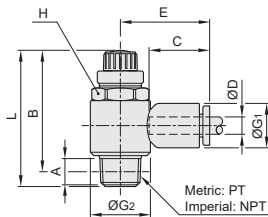

Inch specification

Port size ØD	Thread size NR(NPT)	Model	A	B		C	E	L		ØG1	ØG2	Across flats H	Effective orifice mm ²	Weight (g)
				max	min			max	min					
5/32"	NR10/32"	QSC 5/32 - 10/32	3.8	27.8	24.8	14.8	19.9	29.7	26.7	10.5	10	8	4	10
	1/8"	QSC 5/32 - 01	6	35.4	31.6	14.6	21.6	38.4	34.6	10.5	14.2	12	5.5	20
	1/4"	QSC 5/32 - 02	9	37	33.4	14.6	21.6	41.5	37.9	10.5	18.6	17	12.5	34
1/4"	3/8"	QSC 5/32 - 03	10	45.3	40.2	17.1	21.8	29.7	26.7	12.4	10	8	4	10
	1/8"	QSC 1/4 - 01	6	35.4	31.6	17.1	23.7	38.4	34.6	12.4	14.2	12	5.5	20
	1/4"	QSC 1/4 - 02	9	37	33.4	17.1	25.9	41.5	37.9	12.4	18.6	17	12.5	36
5/16"	3/8"	QSC 1/4 - 03	10	45.3	40.2	17.1	28	50.3	45.2	12.4	23	19	20	60
	1/8"	QSC 5/16 - 01	6	35.4	31.6	18.9	25.5	38.4	34.6	14.3	14.2	12	5.5	20
	1/4"	QSC 5/16 - 02	9	37	33.4	18.9	27.7	41.5	37.9	14.3	18.6	17	12.5	36
3/8"	3/8"	QSC 5/16 - 03	10	45.3	40.2	18.9	29.9	50.3	45.2	14.3	23	19	20	60
	1/4"	QSC 3/8 - 02	9	37	33.4	20.4	29.6	41.5	37.9	17.8	18.6	17	12.5	40
	3/8"	QSC 3/8 - 03	10	45.3	40.2	20.4	31.7	50.3	45.2	17.8	23	19	20	64
1/2"	1/2"	QSC 3/8 - 04	14	55	46.6	20.3	34.6	62	53.6	17.8	28.8	24	35	98
	3/8"	QSC 1/2 - 03	10	45.3	40.2	22.8	35	50.3	45.2	21.5	21.2	19	20	68
	1/2"	QSC 1/2 - 04	14	55	46.6	22.8	37.2	62	53.6	21.5	28.8	24	35	102

QSM series Speed Controller - Mini Type

Product features

CHELIC

Specification

● Metric

Unit: mm

Model	Port size	Thread size (PT)		
		M3	M5	1/8"
QSM 4 – □	Ø4	●	●	●
QSM 6 – □	Ø6	●	●	●

Flow rate characteristic graph

● QSM 4 – M3

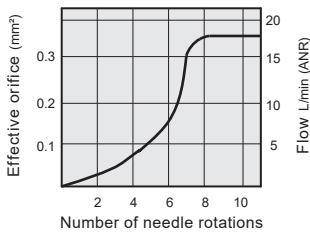

● QSM 4 – M5

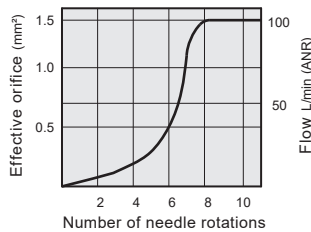

● QSM 6 – 01

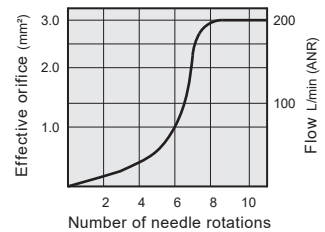

QSM series Speed controller - Mini type



Metric specification

Port size ØD	Thread size PT	Model	A	B		C	E	L		ØG1	ØG2	Across flats H	Effective orifice mm²	Weight (g)
				max	min			max	min					
Ø4	M3	QSM 4 - M3	3.3	24.5	23.5	10.5	15.5	26.3	25.3	9	10	8	0.3	3.7
	M5	QSM 4 - M5	3	24.6	23.6	10.5	15.5	26.2	25.3					
	PT 1/8"	QSM 4 - 01	6.5	29.1	27.6	10.4	17.5	32.8	31.4					
Ø6	M3	QSM 6 - M3	3.3	24.5	23.5	12.6	17.3	26.3	25.3	11.4	10	8	0.3	6.8
	M5	QSM 6 - M5	3	24.6	23.6	12.6	17.3	26.2	25.3					
	PT 1/8"	QSM 6 - 01	6.5	29.1	27.6	11.9	18.5	32.5	31.4					

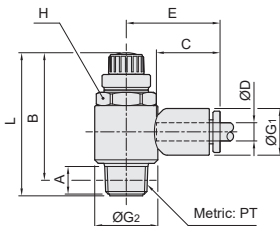

SQ □

MSQ □

SP □

SQ □ J

SQR □

SQ □ G

RQL

M □

Stainless steel fitting

Brass Fitting

Full copper fitting

□ SC

QS □

QMC

QT

QH □

QV □

QST

PU Tube

QSU series Speed Controller - Universal Type

Product features

CHELIC

Internal structure

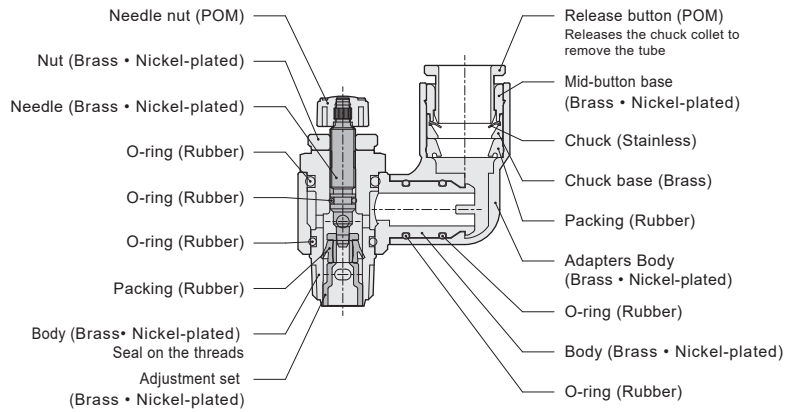

Specification

Item	Port size	Ø4, Ø6, Ø8, Ø10, Ø12, 5/32", 5/16", 3/8"
Fluid		Air
Pressure range	kgf/cm ² (kPa)	0 ~ 9 (0 ~ 900)
Proof pressure	kgf/cm ² (kPa)	10 (1000)
Number of needle rotation		10 (8) round
Ambient and fluid temperature	°C	5 ~ 60
Material	Body	Brass (Nickel-plated)
	Plastic	NYLON, PBT, PP
Thread	Rc (PT/NPT)	M5x0.8p, (10/32"), 1/8", 1/4", 3/8", 1/2"
Seal on the threads		With sealant

Code of order

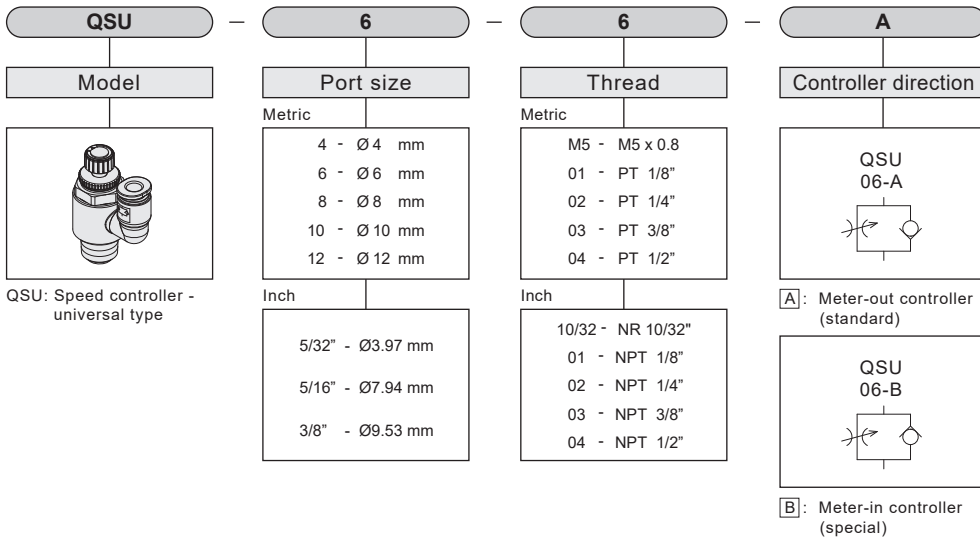

QSU series Speed Controller - Universal Type

Product features

CHELIC

Specification

● Metric

Unit: mm

Model	Port size	Thread size (PT)				
		M5	1/8"	1/4"	3/8"	1/2"
QSU 4 - □	Ø4	●	●	●		
QSU 6 - □	Ø6	●	●	●	●	
QSU 8 - □	Ø8		●	●	●	
QSU 10 - □	Ø10			●	●	●
QSU 12 - □	Ø12				●	●

● Imperial

Unit: Inch

Model	Port size	Thread size (NR / NPT)				
		10/32"	1/8"	1/4"	3/8"	1/2"
QSU 5/32" - □	5/32"	●	●	●		
QSU 5/16" - □	5/16"		●	●	●	
QSU 3/8" - □	3/8"			●	●	●

Control direction for speed controller

- **A** Meter-out controller(standard)

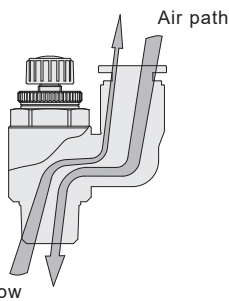

- **B** Meter-in controller

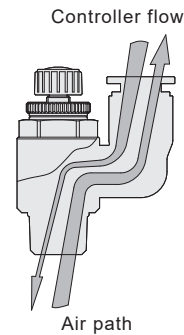

Flow rate characteristic graph

● QSU 4 - M5

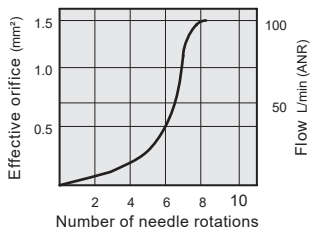

● QSU 6 - 01

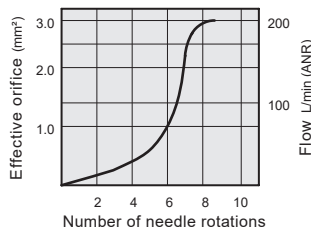

● QSU 8 - 02

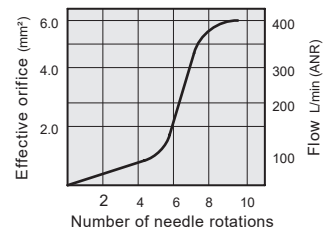

● QSU 10 - 03

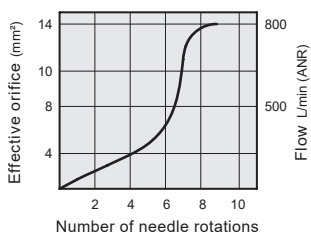

● QSU 12 - 04

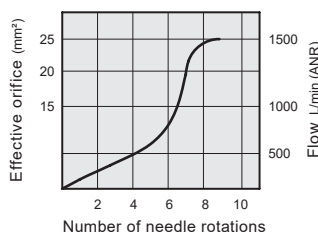

SQ □

MSQ □

SP □

SQ □ J

SQR □

SQ □ G

RQL

M □

Stainless steel fitting

Brass Fitting

Full copper fitting

□ SC

QS □

QMC

QT

QH □

QV □

QST

PU Tube

QSU series Speed Controller - Universal Type

Dimensions

CHELIC

QSU series Speed controller - Universal type

Metric specification

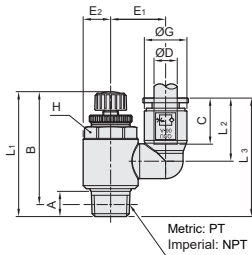

Port size ØD	Thread size PT	Model	A	B		C	E1	E2	ØG	L1		L2	L3	Across flats H	Effective orifice mm ²	Weight (g)
				max	min					max	min					
Ø4	M5	QSU 4 - M5	3.8	27.8	24.8	10.2	10.9	5	9	29.7	26.7	14	24.3	8	4	10
	1/8"	QSU 4 - 01	6	35.4	31.6		13	7.1		38.4	34.6		28.3	12	5.5	20
	1/4"	QSU 4 - 02	9	37	33.4		15.2	9.3		41.5	37.9		31.5	17	12.5	34
Ø6	M5	QSU 6 - M5	3.8	27.8	24.8	11.9	12.1	5	11	29.7	26.7	16.3	26.6	8	4	10
	1/8"	QSU 6 - 01	6	35.4	31.6		14.2	7.1		38.4	34.6		30.6	12	5.5	20
	1/4"	QSU 6 - 02	9	37	33.4		16.4	9.3		41.5	37.9		33.8	17	12.5	36
	3/8"	QSU 6 - 03	10	45.3	40.2		18.6	11.5		50.3	45.2		39	19	20	60
Ø8	1/8"	QSU 8 - 01	6	35.4	31.6	17	19.3	7.1	14.3	38.4	34.6	22.8	37.1	12	5.5	20
	1/4"	QSU 8 - 02	9	37	33.4		21.5	9.3		41.5	37.9		39.8	17	12.5	36
	3/8"	QSU 8 - 03	10	45.3	40.2		23.7	11.5		50.3	45.2		45.5	19	20	60
Ø10	1/4"	QSU 10 - 02	9	37	33.4	20	23.8	9.3	17.8	41.5	37.9	26.5	43.1	17	12.5	40
	3/8"	QSU 10 - 03	10	45.3	40.2		26	11.5		50.3	45.2		49.2	19	20	64
	1/2"	QSU 10 - 04	14	55	46.6		28.9	14.4		62	53.6		53.3	24	35	98
Ø12	3/8"	QSU 12 - 03	10	45.3	40.2	21.3	28.4	10.6	21.1	50.3	45.2	29.6	51.3	19	20	68
	1/2"	QSU 12 - 04	14	55	46.6		31.3	14.4		62	53.6		56.4	24	35	102

Inch specification

Port size ØD	Thread size NR/ NPT	Model	A	B		C	E1	E2	ØG	L1		L2	L3	Across flats H	Effective orifice mm ²	Weight (g)
				max	min					max	min					
5/32"	10/32"	QSU 5/32 - M5	3.8	27.8	24.8	10.2	10.9	5	9	29.7	26.7	14	24.3	8	4	10
	1/8"	QSU 5/32 - 01	6	35.4	31.6		13	7.1		38.4	34.6		28.3	12	5.5	20
	1/4"	QSU 5/32 - 02	9	37	33.4		15.2	9.3		41.5	37.9		31.5	17	12.5	34
5/16"	1/8"	QSU 5/16 - 01	6	35.4	31.6	17	19.3	7.1	14.3	38.4	34.6	22.8	37.1	12	5.5	20
	1/4"	QSU 5/16 - 02	9	37	33.4		21.5	9.3		41.5	37.9		39.8	17	12.5	36
	3/8"	QSU 5/16 - 03	10	45.3	40.2		23.7	11.5		50.3	45.2		45.5	19	20	60
3/8"	1/4"	QSU 3/8 - 02	9	37	33.4	20	23.8	9.3	17.8	41.5	37.9	26.5	43.1	17	12.5	40
	3/8"	QSU 3/8 - 03	10	45.3	40.2		26	11.5		50.3	45.2		49.2	19	20	64
	1/2"	QSU 3/8 - 04	14	55	46.6		28.9	14.4		62	53.6		53.3	24	35	98

QSB series Speed Controller - Large Flow Type

Product features/ Code of order

CHELIC

Internal structure

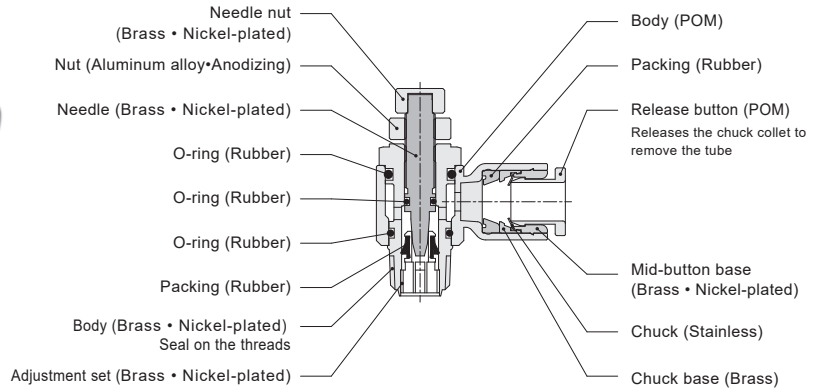

For controlling large flow rate, suitable for high speed actuating cylinder.

Specification

Item	Port size	Ø4, Ø6, Ø8, Ø10, Ø12, 5/32", 1/4", 5/16", 3/8", 1/2"
Fluid		Air
Pressure range	kgf/cm ² (kPa)	0 ~ 9 (900)
Proof pressure	kgf/cm ² (kPa)	10 (1000)
Number of needle rotation		10 (8) round
Ambient and fluid temperature	°C	0 ~ 60
Material	Body	Brass (Nickel-plated)
	Plastic	NYLON, POM
Thread	Rc (PT/ NPT)	1/8", 1/4", 3/8", 1/2"
Seal on the threads		With sealant

Code of order

QSB - 6 - 01 - A

Model - Port size - Thread - Control direction

QSB : Speed Controller - Large flow type

Port size

Metric

- 4 - Ø4 mm
- 6 - Ø6 mm
- 8 - Ø8 mm
- 12 - Ø12 mm
- 10 - Ø10 mm

Inch

- 5/32" - Ø3.97 mm
- 1/4" - Ø6.35 mm
- 5/16" - Ø7.94 mm
- 3/8" - Ø9.53 mm
- 1/2" - Ø12.7 mm

Thread

Metric

- 01 - PT 1/8"
- 02 - PT 1/4"
- 03 - PT 3/8"
- 04 - PT 1/2"

Inch

- 01 - NPT 1/8"
- 02 - NPT 1/4"
- 03 - NPT 3/8"
- 04 - NPT 1/2"

Control direction

[A]: Meter-out controller (standard)

[B]: Meter-in controller (special)

SQ

MSQ

SP

SQ J

SQR

SQ G

RQL

M

Stainless steel fitting

Brass Fitting

Full copper fitting

SC

QS

QMC

QT

QH

QV

QST

PU Tube

QSB series Speed Controller - Large Flow Type

Product features

CHELIC

Specification

● Metric

Unit: mm

Model	Port size	Thread size (PT)			
		1/8"	1/4"	3/8"	1/2"
QSB 4 - □	Ø4	●	●		
QSB 6 - □	Ø6	●	●	●	
QSB 8 - □	Ø8	●	●	●	
QSB 10 - □	Ø10		●	●	●
QSB 12 - □	Ø12			●	●

● Imperial

Unit: Inch

Model	Port size	Thread size (NR / NPT)			
		1/8"	1/4"	3/8"	1/2"
QSB 5/32" - □	5/32"	●	●		
QSB 1/4" - □	1/4"	●	●	●	
QSB 5/16" - □	5/16"	●	●	●	
QSB 3/8" - □	3/8"		●	●	●
QSB 1/2" - □	1/2"			●	●

Control direction for speed controller

- **A** Meter-out controller(standard)

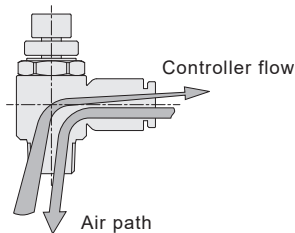

- **B** Meter-in controller

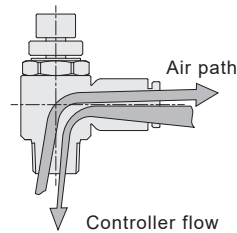

Flow rate characteristic graph

● QSB 04 - 01 ● QSB 08 - 01
● QSB 06 - 01

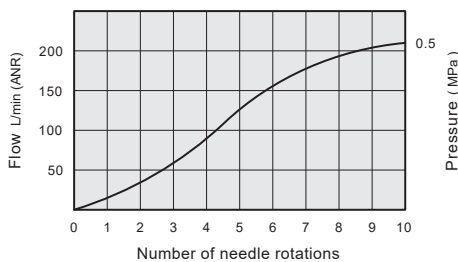

● QSB 04 - 02 ● QSB 08 - 02
● QSB 06 - 02 ● QSB 10 - 02

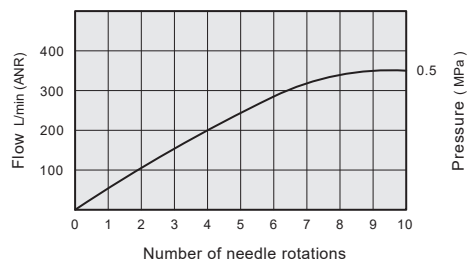

● QSB 06 - 03 ● QSB 10 - 03
● QSB 08 - 03 ● QSB 12 - 03

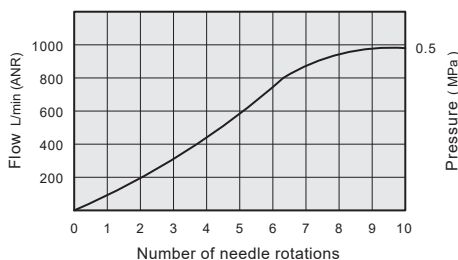

● QSB 10 - 04
● QSB 12 - 04

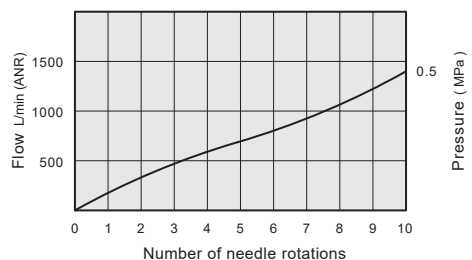

QSB series Speed Controller - Large Flow Type

Dimensions

CHELIC

QSB series Speed controller - Large flow type

Metric specification

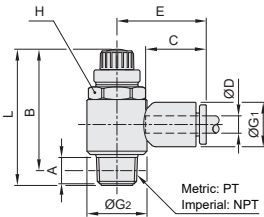

Port size ØD	Thread size Rc (PT)	Model	A	B		C	E	L		ØG1	ØG2	Across flats H	Weight (g)
				max	min			max	min				
Ø4	1/8"	QSB 4 - 01	5.5	34.5	29.4	14.6	21.5	38.5	33.4	10.5	14.2	12	19
	1/4"	QSB 4 - 02	8.5	34.6	30.4	14.6	24	41.6	37.4	12.4	18.6	17	34
Ø6	1/8"	QSB 6 - 01	5.5	34.5	29.4	17	23.6	38.5	33.4	12.4	14.2	12	20
	1/4"	QSB 6 - 02	8.5	34.6	30.4	17	25.8	41.6	37.4	12.4	18.6	17	35
	3/8"	QSB 6 - 03	11	40.6	35.5	17	27.9	50.3	45.2	12.4	23	19	58
Ø8	1/8"	QSB 8 - 01	5.5	34.5	29.4	18.6	25.4	38.5	33.4	14.3	14.2	12	21
	1/4"	QSB 8 - 02	8.5	34.6	30.4	18.6	27.6	41.6	37.4	14.3	18.6	17	36
	3/8"	QSB 8 - 03	11	40.6	35.5	18.6	29.8	50.3	45.2	14.3	23	19	59
Ø10	1/4"	QSB 10 - 02	8.5	34.6	30.4	20.4	29.5	41.6	37.4	17.8	18.6	17	39
	3/8"	QSB 10 - 03	11	40.6	35.5	20.4	31.6	50.3	45.2	17.8	23	19	63
	1/2"	QSB 10 - 04	12.5	47.8	40.2	20.4	34.6	58.2	50.6	17.8	28.8	24	101
Ø12	3/8"	QSB 12 - 03	8.5	40.6	35.5	22.8	34.2	50.3	45.2	21.5	23	19	68
	1/2"	QSB 12 - 04	12.5	47.8	40.2	22.8	37.2	58.2	50.6	21.5	28.8	24	106

Inch specification

Port size ØD	Thread size NR(NPT)	Model	A	B		C	E	L		ØG1	ØG2	Across flats H	Weight (g)
				max	min			max	min				
5/32"	1/8"	QSB 5/32 - 01	5.5	34.5	29.4	14.6	21.5	38.5	33.4	10.5	14.2	12	19
	1/4"	QSB 5/32 - 02	8.5	34.6	30.4	14.6	24	41.6	37.4	12.4	18.6	17	34
1/4"	1/8"	QSB 1/4 - 01	5.5	34.5	29.4	17	23.6	38.5	33.4	12.4	14.2	12	20
	1/4"	QSB 1/4 - 02	8.5	34.6	30.4	17	25.8	41.6	37.4	12.4	18.6	17	35
	3/8"	QSB 1/4 - 03	11	40.6	35.5	17	27.9	50.3	45.2	12.4	23	19	58
5/16"	1/8"	QSB 5/16 - 01	5.5	34.5	29.4	18.6	25.4	38.5	33.4	14.3	14.2	12	21
	1/4"	QSB 5/16 - 02	8.5	34.6	30.4	18.6	27.6	41.6	37.4	14.3	18.6	17	36
	3/8"	QSB 5/16 - 03	11	40.6	35.5	18.6	29.8	50.3	45.2	14.3	23	19	59
3/8"	1/4"	QSB 3/8 - 02	8.5	34.6	30.4	20.4	29.5	41.6	37.4	17.8	18.6	17	39
	3/8"	QSB 3/8 - 03	11	40.6	35.5	20.4	31.6	50.3	45.2	17.8	23	19	63
	1/2"	QSB 3/8 - 04	12.5	47.8	40.2	20.4	34.6	58.2	50.6	17.8	28.8	24	101
1/2"	3/8"	QSB 1/2 - 03	8.5	40.6	35.5	22.8	34.2	50.3	45.2	21.5	23	19	68
	1/2"	QSB 1/2 - 04	12.5	47.8	40.2	22.8	37.2	58.2	50.6	21.5	28.8	24	106

SQ

MSQ

SP

SQ J

SQR

SQ G

RQL

M

Stainless steel fitting

Brass Fitting

Full copper fitting

SC

QS

QMC

QT

QH

QV

QST

PU Tube

QSS series Speed Controller - Low Flow Type

Product features/ Code of order

CHELIC

Internal structure

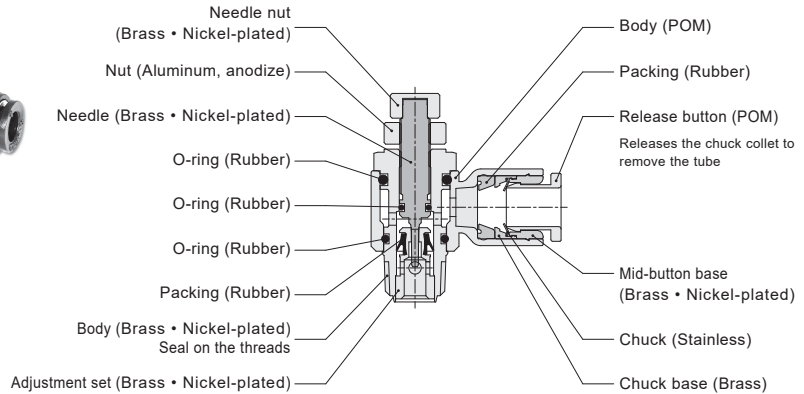

For controlling small flow rate, suitable for low speed actuating cylinder.

Specification

Item	Port size	Ø4, Ø6, Ø8, Ø10, 5/32", 1/4", 5/16", 3/8"
Fluid		Air
Pressure range	kgf/cm ² (kPa)	0 ~ 9 (900)
Proof pressure	kgf/cm ² (kPa)	10 (1000)
Number of needle rotation		10 (12) round
Ambient and fluid temperature	°C	0 ~ 60
Material	Body	Brass (Nickel-plated)
	Plastic	NYLON, POM
Thread	Rc (PT/ NPT)	M5x0.8p (10/32"), 1/8", 1/4"
Seal on the threads		With sealant

Code of order

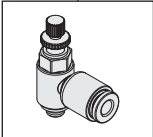
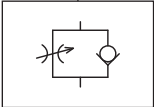
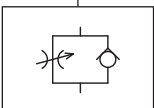
QSS	-	6	-	01	-	A
Model		Port size		Thread		Control direction
		Metric		Metric		
QSS : Speed controller - Low Flow Type		4 - Ø4 mm 6 - Ø6 mm 8 - Ø8 mm 10 - Ø10 mm		M5 - M5x0.8p 01 - PT 1/8" 02 - PT 1/4"		A : Meter-out controller (standard)
		Inch		Inch		
		5/32" - Ø3.97 mm 1/4" - Ø6.35 mm 5/16" - Ø7.94 mm 3/8" - Ø9.53 mm		10/32" - NR10/32" 01 - NPT1/8" 02 - NPT1/4"		B : Meter-in controller (special)

QSS series Speed Controller - Low Flow Type

Product features

CHELIC

Specification

● Metric

Unit: mm

Model	Port size	Thread size (PT)		
		M5	1/8"	1/4"
QSS 4 - <input type="checkbox"/>	Ø4	●	●	
QSS 6 - <input type="checkbox"/>	Ø6	●	●	●
QSS 8 - <input type="checkbox"/>	Ø8		●	●
QSS 10 - <input type="checkbox"/>	Ø10			●

● Imperial

Unit: Inch

Model	Port size	Thread size (NR / NPT)		
		10/32"	1/8"	1/4"
QSS 5/32" - <input type="checkbox"/>	5/32"	●	●	
QSS 1/4" - <input type="checkbox"/>	1/4"	●	●	●
QSS 5/16" - <input type="checkbox"/>	5/16"		●	●
QSS 3/8" - <input type="checkbox"/>	3/8"			●

Control direction for speed controller

- A Meter-out controller(standard)

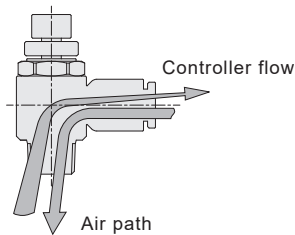

- B Meter-in controller

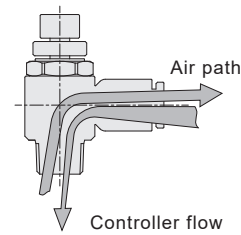

Flow rate characteristic graph

● QSS 04 - M5
● QSS 06 - M5

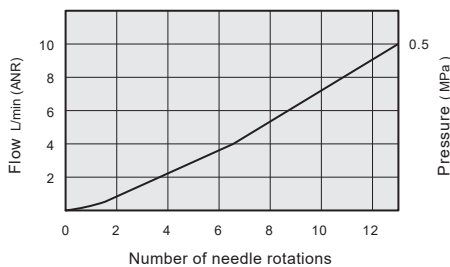

● QSS 04 - 01 ● QSS 08 - 01
● QSS 06 - 01

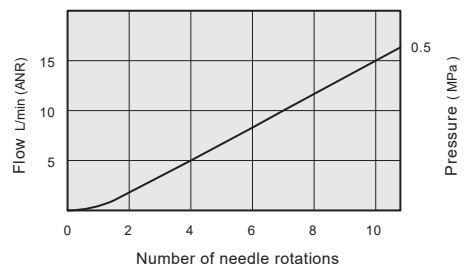

● QSS 06 - 02 ● QSS 10 - 02
● QSS 08 - 02

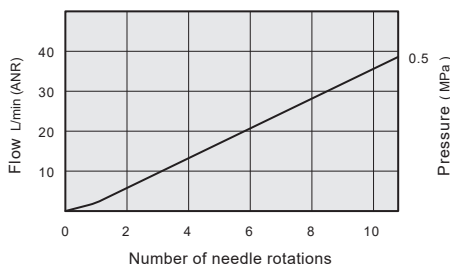

SQ

MSQ

SP

SQ J

SQR

SQ G

RQL

M

Stainless steel fitting

Brass Fitting

Full copper fitting

SC

QS

QMC

QT

QH

QV

QST

PU Tube

QSS series Speed Controller - Low Flow Type

Dimensions

CHELIC

QSS series Speed controller - Low flow type

Metric specification

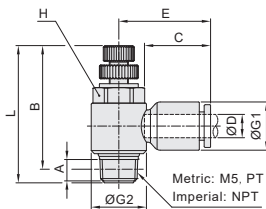

Port size ØD	Thread size Rc (PT)	Model	A	B		C	E	L		ØG1	ØG2	Across flats H	Effective orifice mm ²	Weight (g)
				max	min			max	min					
Ø4	M5	QSS 4 - M5	3.2	31.8	27.3	14.6	19.9	35	30.5	10.5	10	8	0.1	9
	1/8"	QSS 4 - 01	5.5	34.6	29.4	14.6	21.5	38.4	33.4	10.5	14.2	12	0.2	19
Ø6	M5	QSS 6 - M5	3.2	32.3	27.8	17	21.7	35	30.5	12.4	10	8	0.1	10
	1/8"	QSS 6 - 01	5.5	34.6	29.4	17	23.6	38.4	33.4	12.4	14.2	12	0.1	20
	1/4"	QSS 6 - 02	8.5	34.5	30.3	17	25.8	41.6	37.4	12.4	18.6	17	0.6	35
Ø8	1/8"	QSS 8 - 01	5.5	34.6	29.4	18.6	25.4	38.4	33.4	14.3	14.2	12	0.1	21
	1/4"	QSS 8 - 02	8.5	34.5	30.3	18.6	27.6	41.6	37.4	14.3	18.6	17	0.6	36
Ø10	1/4"	QSS 10 - 02	8.5	34.5	30.3	20.9	29.5	41.6	37.4	17.8	18.6	17	0.6	39

Inch specification

Port size ØD	Thread size NR/ NPT	Model	A	B		C	E	L		ØG1	ØG2	Across flats H	Effective orifice mm ²	Weight (g)
				max	min			max	min					
5/32"	NR10/32"	QSS 5/32 - 10/32	3.2	31.8	27.3	14.6	19.9	35	30.5	10.5	10	8	0.1	9
	1/8"	QSS 5/32 - 01	5.5	34.6	29.4	14.6	21.5	38.4	33.4	10.5	14.2	12	0.2	19
1/4"	NR10/32"	QSS 1/4 - 10/32	3.2	32.3	27.8	17	21.7	35	30.5	12.4	10	8	0.1	10
	1/8"	QSS 1/4 - 01	5.5	34.6	29.4	17	23.6	38.4	33.4	12.4	14.2	12	0.1	20
	1/4"	QSS 1/4 - 02	8.5	34.5	30.3	17	25.8	41.6	37.4	12.4	18.6	17	0.6	35
5/16"	1/8"	QSS 5/16 - 01	5.5	34.6	29.4	18.6	25.4	38.4	33.4	14.3	14.2	12	0.1	21
	1/4"	QSS 5/16 - 02	8.5	34.5	30.3	18.6	27.6	41.6	37.4	14.3	18.6	17	0.6	36
3/8"	1/4"	QSS 3/8 - 02	8.5	34.5	30.3	20.9	29.5	41.6	37.4	17.8	18.6	17	0.6	39

QSN series Speed Controller In-line

Product features/ Code of order

CHELIC



Internal structure

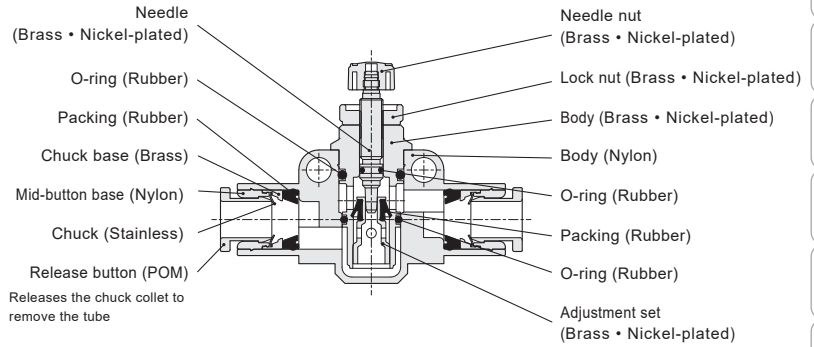

Specification

Item	Port size	Ø4, Ø6, Ø8, Ø10, Ø12, 5/32", 1/4", 5/16", 3/8", 1/2"
Fluid		Air
Pressure range	kgf/cm ² (kPa)	0 ~ 9 (0 ~ 900)
Proof pressure	kgf/cm ² (kPa)	10 (1000)
Number of needle rotation		10 (8) round
Ambient and fluid temperature	°C	5 ~ 60
Material	Body	Brass (Nickel-plated)
	Plastic	NYLON, PBT, PP
Thread	Rc (PT/NPT)	1/8", 1/4", 3/8"
Seal on the threads		With sealant

Code of order

QSN	6	01	A
Model	Port size	Thread	Controller direction
	Metric 4 - Ø4 mm 6 - Ø6 mm 8 - Ø8 mm 10 - Ø10 mm 12 - Ø12 mm	Metric 01 - PT 1/8" 02 - PT 1/4" 03 - PT 3/8"	
	Inch 5/32" - Ø3.97 mm 1/4" - Ø6.35 mm 5/16" - Ø7.94 mm 3/8" - Ø9.53 mm 1/2" - Ø12.7 mm	Inch 01 - NPT 1/8" 02 - NPT 1/4" 03 - NPT 3/8"	
	None: No option for QSN	None: No option for QSN	A: Meter-out controller (standard) B: Meter-in controller (special)

SQ

MSQ

SP

SQ J

SQR

SQ G

RQL

M

Stainless steel fitting

Brass Fitting

Full copper fitting

SC

QS

QMC

QT

QH

QV

QST

PU Tube

QSN series Speed Controller In-line

Product features

CHELIC

Control direction for speed controller

- **A** Meter-out controller(standard)

- **B** Meter-in controller

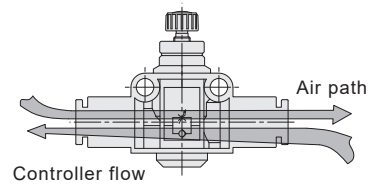
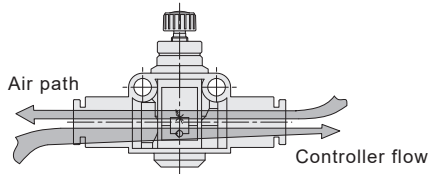

Flow rate characteristic graph

● QSN **4** , **5/32"**

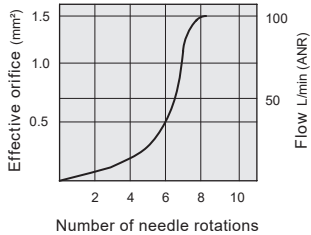

● QSN **6** , **1/4"**

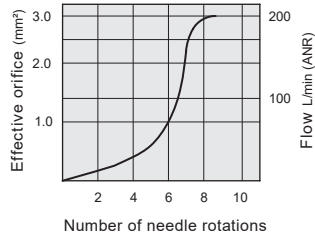

● QSN **8** , **5/16"**

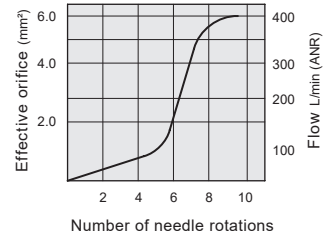

● QSN **10** , **3/8"**

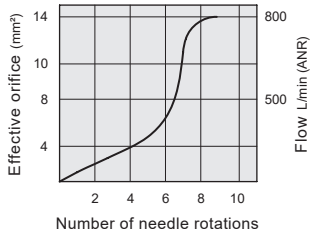

● QSN **12** , **1/2"**

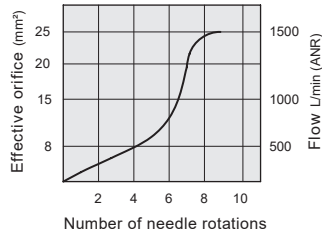

QSN series Speed Controller In-line

Dimensions

CHELIC

QSN series Speed controller in-line

Metric specification



Port size ØD1	Port size ØD2	Model	B	C	Ød	E		F ₁	F ₂	L		ØG	Effective orifice mm ²	Weight (g)
						max	min			max	min			
Ø4	Ø4	QSN 4	41.4	14.6	3.2	14.2	11	6.9	14	26.5	25.3	10.5	4	12
Ø6	Ø6	QSN 6	49.2	16.6	4.3	19.7	14.9	8.5	18	39.3	34.5	12.8	5.5	26
Ø8	Ø8	QSN 8	55.1	17.9	4.3	21.3	18.5	9.6	22	45	42.2	14.5	12.5	42
Ø10	Ø10	QSN 10	62.9	19.3	4.3	23.7	18.8	11.6	26	45.2	43.3	17.8	20	70
Ø12	Ø12	QSN 12	73.5	21.8	4.3	28.9	22.3	11.7	32	54.8	48.2	21.2	35	115

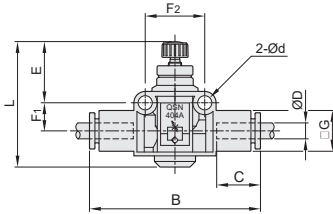

Inch specification

Port size ØD1	Port size ØD2	Model	B	C	Ød	E		F ₁	F ₂	L		ØG	Effective orifice mm ²	Weight (g)
						max	min			max	min			
5/32"	5/32"	QSN 5/32	41.4	14.6	3.2	14.2	11	6.9	14	26.5	25.3	10.5	4	12
1/4"	1/4"	QSN 1/4	49.2	16.6	4.3	19.7	14.9	8.5	18	39.3	34.5	12.8	5.5	26
5/16"	5/16"	QSN 5/16	55.1	17.9	4.3	21.3	18.5	9.6	22	45	42.2	14.5	12.5	42
3/8"	3/8"	QSN 3/8	62.9	19.3	4.3	23.7	18.8	11.6	26	45.2	43.3	17.8	20	70
1/2"	1/2"	QSN 1/2	73.5	21.8	4.3	28.9	22.3	11.7	32	54.8	48.2	21.2	35	115

QSMN series Speed controller - One side port thread

Metric specification

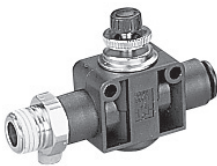

Port size ØD	Thread size Rc(PT)	Model	A	B	C	Ød	E		F ₁	F ₂	L		ØG	Across flats H	Effective orifice mm ²	Weight (g)
							max	min			max	min				
Ø4	1/8"	QSMN 4 - 01	6	49	14.6	3.2	14.2	11	6.9	14	28.5	25.3	10.5	14	5.5	22
	1/4"	QSMN 4 - 02	9	52												
Ø6	1/8"	QSMN 6 - 01	6	56.9	16.6	4.3	19.7	14.9	8.5	18	39.3	34.5	12.8	14	12	36
	1/4"	QSMN 6 - 02	9	60.3												
Ø8	1/4"	QSMN 8 - 02	9	66.7	17.9	4.3	21.3	18.5	9.6	22	45	42.2	14.5	19	16	62
	3/8"	QSMN 8 - 03	9	66.7												

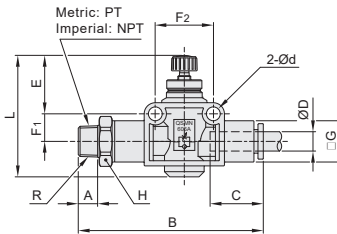

Inch specification

Port size ØD	Thread size NPT	Model	A	B	C	Ød	E		F ₁	F ₂	L		ØG	Across flats H	Effective orifice mm ²	Weight (g)
							max	min			max	min				
5/32"	1/8"	QSMN 5/32 - 1/8	6	49	14.6	3.2	14.2	11	6.9	14	28.5	25.3	10.5	14	5.5	22
	1/4"	QSMN 5/32 - 1/4	9	52												
1/4"	1/8"	QSMN 1/4 - 1/8	6	56.9	16.6	4.3	19.7	14.9	8.5	18	39.3	34.5	12.8	14	12	36
	1/4"	QSMN 1/4 - 1/4	9	60.3												
5/16"	1/4"	QSMN 5/16 - 1/4	9	66.7	17.9	4.3	21.3	18.5	9.6	22	45	42.2	14.5	19	16	62
	3/8"	QSMN 5/16 - 3/8	9	66.7												

QSNN series Speed controller - Tow side port thread

Metric specification

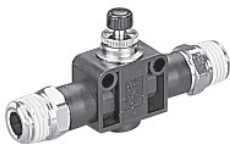

Thread size Rc (PT)	Model	A	B	Ød	E		F ₁	F ₂	L		ØG	Across flats H	Effective orifice mm ²	Weight (g)
					max	min			max	min				
1/8"	QSNN 01	6	56.9	3.2	14.2	11	6.9	14	29.8	27.4	10.5	14	5.5	30
														38
1/4"	QSNN 02	9	71.4	4.3	19.7	14.9	8.5	18	41.9	37.7	12.8	14	12	42
														48
3/8"	QSNN 03	9	78.3	4.3	21.3	18.5	9.6	22	47.6	40.3	14.5	19	16	78
														82

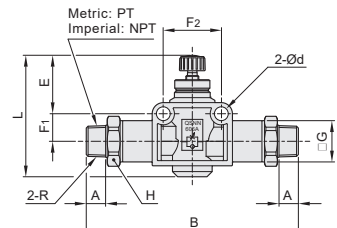

Inch specification

Thread size NPT	Model	A	B	Ød	E		F ₁	F ₂	L		ØG	Across flats H	Effective orifice mm ²	Weight (g)
					max	min			max	min				
1/8"	QSNN 1/8	6	56.9	3.2	14.2	11	6.9	14	29.8	27.4	10.5	14	5.5	30
														38
1/4"	QSNN 1/4	9	71.4	4.3	19.7	14.9	8.5	18	41.9	37.7	12.8	14	12	42
														48
3/8"	QSNN 3/8	9	78.3	4.3	21.3	18.5	9.6	22	47.6	40.3	14.5	19	16	78
														82

SQ □

MSQ □

SP □

SQ □ J

SQR □

SQ □ G

RQL

M □

Stainless steel fitting

Brass Fitting

Full copper fitting

□ SC

QS □

QMC

QT

QH □

QV □

QST

PU Tube

QMC series Speed Controller With Metal Body

Product features/ Code of order

CHELIC

Internal structure

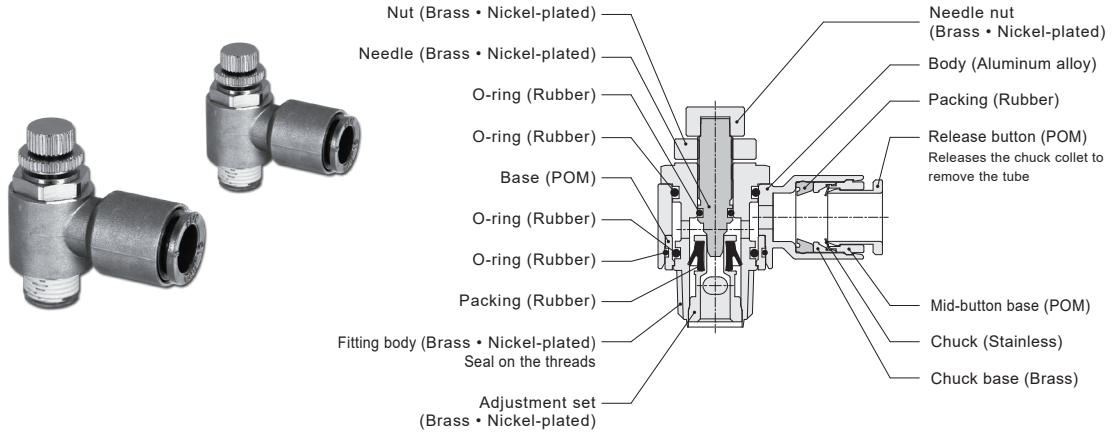

● Suitable for flammable place.

Specification

Item	Port size	Ø4, Ø6, Ø8, Ø10, Ø12, 5/32", 1/4", 5/16", 3/8"
Fluid		Air
Pressure range	kgf/cm ² (kPa)	0 ~ 9 (900)
Proof pressure	kgf/cm ² (kPa)	10 (1000)
Number of needle rotation		10 (8) round
Ambient and fluid temperature	°C	5 ~ 60
Material	Body	Die-casting alloy
	Fitting body	Brass (Nickel-plated)
	Plastic	POM
Thread	Rc (PT/ NPT)	M5x0.8p (10/32"), 1/8", 1/4", 3/8", 1/2"
Seal on the threads		With sealant

Code of order

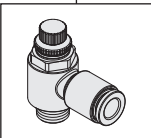
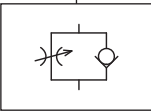
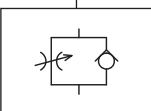
QMC	-	6	-	01	-	A
Model		Port size		Thread		Control direction
		Metric		Metric		
QMC: Speed controller with metal body		4 - Ø4 mm 6 - Ø6 mm 8 - Ø8 mm 10 - Ø10 mm 12 - Ø12 mm		M5 - M5x0.8p 01 - PT 1/8" 02 - PT 1/4" 03 - PT 3/8" 04 - PT 1/2"		[A]: Meter-out controller (standard)
		Inch		Inch		
		5/32" - Ø3.97 mm 1/4" - Ø6.35 mm 5/16" - Ø7.94 mm 3/8" - Ø9.53 mm		10/32" - NR10/32" 01 - NPT 1/8" 02 - NPT 1/4" 03 - NPT 3/8" 04 - NPT 1/2"		[B]: Meter-in controller (special)

QMC series Speed Controller With Metal Body

Product features

CHELIC

Specification

● Metric

Unit: mm

Model	Port size	Thread size (PT)				
		M5	1/8"	1/4"	3/8"	1/2"
QMC 4 - <input type="checkbox"/>	Ø4	●				
QMC 6 - <input type="checkbox"/>	Ø6	●	●	●		
QMC 8 - <input type="checkbox"/>	Ø8		●	●	●	
QMC 10 - <input type="checkbox"/>	Ø10				●	●
QMC 12 - <input type="checkbox"/>	Ø12					●

● Imperial

Unit: Inch

Model	Port size	Thread size (NR / NPT)				
		10/32"	1/8"	1/4"	3/8"	1/2"
QMC 5/32" - <input type="checkbox"/>	5/32"	●				
QMC 1/4" - <input type="checkbox"/>	1/4"	●	●	●		
QMC 5/16" - <input type="checkbox"/>	5/16"		●	●	●	
QMC 3/8" - <input type="checkbox"/>	3/8"				●	●

Control direction for speed controller

- A Meter-out controller(standard)

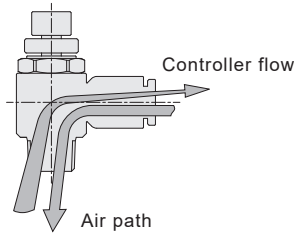

- B Meter-in controller

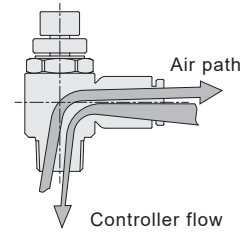

Flow rate characteristic graph

● QMC 4 - M5

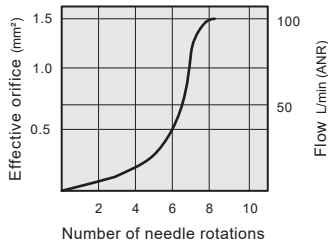

● QMC 6 - 01

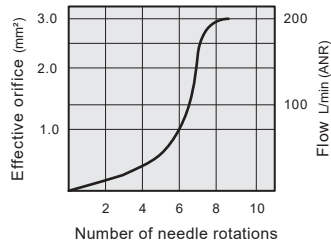

● QMC 8 - 02

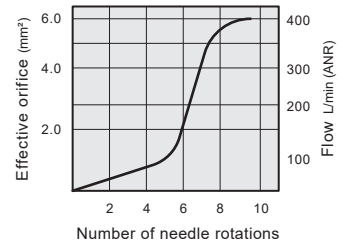

● QMC 10 - 03

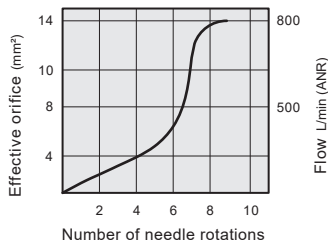

● QMC 12 - 04

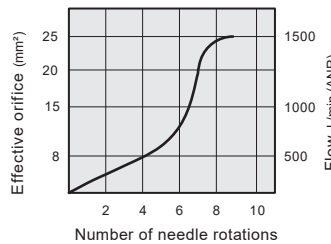

SQ

MSQ

SP

SQ J

SQR

SQ G

RQL

M

Stainless steel fitting

Brass Fitting

Full copper fitting

SC

QS

QMC

QT

QH

QV

QST

PU Tube

QMC series Speed Controller With Metal Body

Dimensions

CHELIC

QMC series Speed controller with metal body

Metric specification

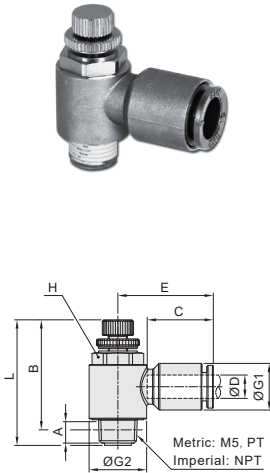

Port size ØD	Thread size Rc (PT)	Model	A	B		C	E	L		ØG1	ØG2	Across flats H	Effective orifice mm ²	Weight (g)
				max	min			max	min					
Ø4	M5	QMC 4 - M5	3.2	25.8	23.3	14.4	21.8	29	26.5	10	12.4	8	4	10
Ø6	M5	QMC 6 - M5	3.2	25.8	23.3	16.6	21.8	29	26.5	10	12.4	8	4	9
	1/8"	QMC 6 - 01	5.5	33	29	17	26.1	37	33	15.2	14.3	12	5.5	22
	1/4"	QMC 6 - 02	8.5	34.2	30	17	28.4	41.2	37	19.6	14.3	17	12.5	21
Ø8	1/8"	QMC 8 - 01	5.5	33	29	18.6	26.3	37	33	15.2	14.3	12	5.5	38
	1/4"	QMC 8 - 02	8.5	34.2	30	18.6	28.6	41.2	37	19.6	14.3	17	12.5	36
	3/8"	QMC 8 - 03	11	39.4	35.4	18.6	32.7	49.1	45.1	24.4	17.8	19	20	72
Ø10	3/8"	QMC 10 - 03	11	39.4	35.4	20.9	33.2	49.1	45.1	24.4	17.8	19	20	70
	1/2"	QMC 10 - 04	12.5	48.1	41.1	20.9	37.7	58.7	51.7	28.6	21.2	24	35	118
Ø12	1/2"	QMC 12 - 04	12.5	48.1	41.1	22.8	37.1	58.7	51.7	28.6	21.2	24	35	116

Inch specification

Port size ØD	Thread size NR/ NPT	Model	A	B		C	E	L		ØG1	ØG2	Across flats H	Effective orifice mm ²	Weight (g)
				max	min			max	min					
5/32"	M5	QMC 5/32-10/32	3.2	25.8	23.3	14.4	21.8	29	26.5	10	12.4	8	4	10
1/4"	M5	QMC 1/4-10/32	3.2	25.8	23.3	16.6	21.8	29	26.5	10	12.4	8	4	9
	1/8"	QMC 1/4 - 01	5.5	33	29	17	26.1	37	33	15.2	14.3	12	5.5	22
	1/4"	QMC 1/4 - 02	8.5	34.2	30	17	28.4	41.2	37	19.6	14.3	17	12.5	21
5/16"	1/8"	QMC 5/16 - 01	5.5	33	29	18.6	26.3	37	33	15.2	14.3	12	5.5	38
	1/4"	QMC 5/16 - 02	8.5	34.2	30	18.6	28.6	41.2	37	19.6	14.3	17	12.5	36
	3/8"	QMC 5/16 - 03	11	39.4	35.4	18.6	32.7	49.1	45.1	24.4	17.8	19	20	72
3/8"	3/8"	QMC 3/8 - 03	11	39.4	35.4	20.9	33.2	49.1	45.1	24.4	17.8	19	20	70
	1/2"	QMC 3/8 - 04	12.5	48.1	41.1	20.9	37.7	58.7	51.7	28.6	21.2	24	35	118

QT series Speed Control Silencer

Product features/ Code of order

CHELIC

Internal structure

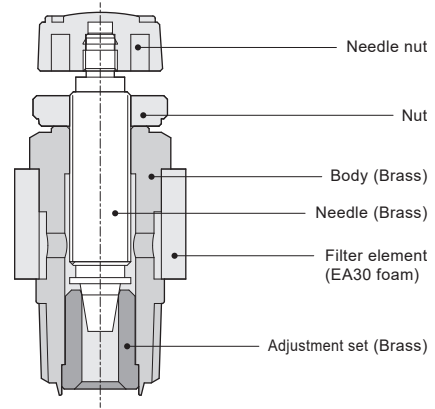

Specification

Item	Model	QT-M5	QT-01	QT-02	QT-03	QT-04
Thread	Rc(PT)	M5x0.8	Rc1/8	Rc1/4	Rc3/8	Rc1/2
Fluid		Air				
Pressure range	kg/cm ² (kPa)	8(800)				
Ambient and fluid temperature	°C	5 ~ 60				

Code of order

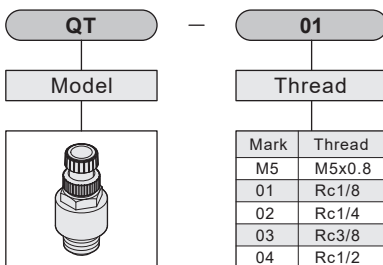

SQ

MSQ

SP

SQ J

SQR

SQ G

RQL

M

Stainless
steel fitting

Brass
Fitting

Full copper
fitting

SC

QS

QMC

QT

QH

QV

QST

PU Tube

QT series Speed Control Silencer

Product features

CHELIC

Flow rate characteristic graph

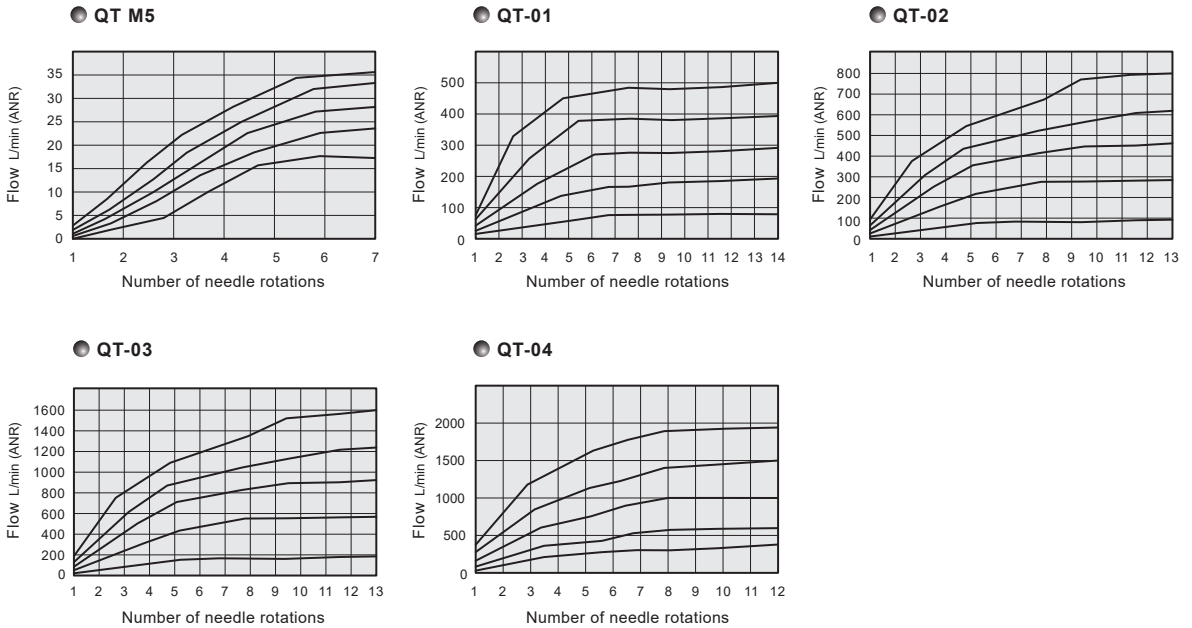

QT series

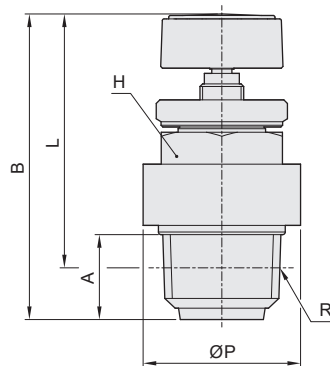

Model	R	A	B		L		ØP	H	Weight (g)
			max	min	max	min			
QT M5	M5x0.8	3.5	23	19	21	17	10	08	4.6
QT 01	Rc1/8	7.5	38	30	35	26	14	10	16
QT 02	Rc1/4	9.7	39	34	34	28	18	14	30
QT 03	Rc3/8	12	43	35	37	29	22	17	54
QT 04	Rc1/2	13	47	40	40	33	27	21	84

QHV series Switching Type In-line

Product features/ Code of order

CHELIC

Internal structure

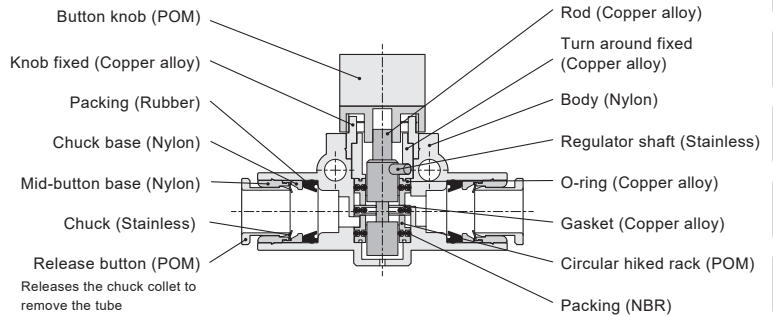

Specification

Item	Port size	Ø4, Ø6, Ø8, Ø10, Ø12, 5/32", 1/4", 5/16", 3/8", 1/2"
Fluid		Air
Pressure range	kgf/cm ² (kPa)	0 ~ 9 (0 ~ 900)
Proof pressure	kgf/cm ² (kPa)	10 (1000)
Proof vacuum pressure	kPa(Torr)	-100 (10)
Ambient and fluid temperature	°C	5 ~ 60
Material	Body	Brass (Nickel-plated)
	Plastic	NYLON, PBT, PP
Thread	Rc (PT/NPT)	1/8", 1/4", 3/8"
Seal on the threads		With sealant

Code of order

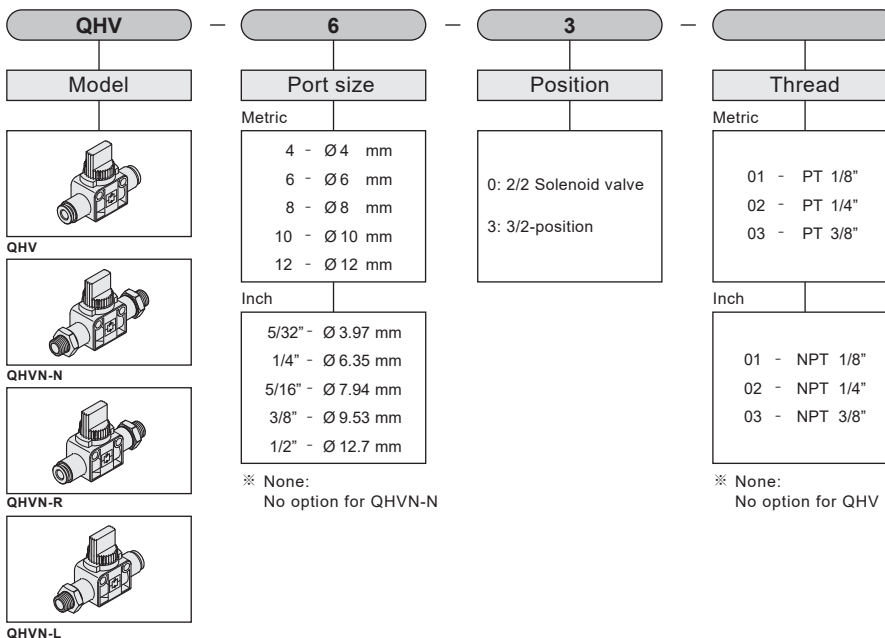

SQ

MSQ

SP

SQ J

SQR

SQ G

RQL

M

Stainless steel fitting

Brass Fitting

Full copper fitting

SC

QS

QMC

QT

QH

QV

QST

PU Tube

QHV series Switching Type In-line

Dimensions

CHELIC

QHV series Switching type in-line

Metric specification



Port size ØD1	Port size ØD2	Model	B ₁	B ₂	ØP ₁	ØP ₂	ØP ₃	C ₁	C ₂	E	F ₁	F ₂	Effective orifice mm ²	Weight (g)
Ø4	Ø4	QHV 4	17.4	41	10.5	10.5	16.5	14.5	14.5	49	18	8	3.4	23
Ø6	Ø6	QHV 6	17.4	41	12.4	12.4	16.5	16.5	16.5	49	18	8	7.2	24
Ø8	Ø8	QHV 8	17.4	41	15	15	16.5	18.5	18.5	54	18	8	8.7	26.5
Ø10	Ø10	QHV 10	21.2	41	17.8	17.8	19.5	20.5	20.5	64	24	11	17.4	49
Ø12	Ø12	QHV 12	21.2	41	21.2	21.2	19.5	22.3	22.3	69.2	24	11	18.1	54.5

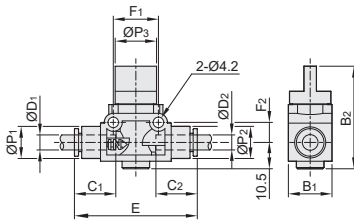

Inch specification

Port size ØD1	Port size ØD2	Model	B ₁	B ₂	ØP ₁	ØP ₂	ØP ₃	C ₁	C ₂	E	F ₁	F ₂	Effective orifice mm ²	Weight (g)
5/32"	5/32"	QHV 5/32	17.4	41	10.5	10.5	16.5	14.5	14.5	49	18	8	3.4	23
1/4"	1/4"	QHV 1/4	17.4	41	12.4	12.4	16.5	16.5	16.5	49	18	8	7.2	24
5/16"	5/16"	QHV 5/16	17.4	41	15	15	16.5	18.5	18.5	54	18	8	8.7	26.5
3/8"	3/8"	QHV 3/8	21.2	41	17.8	17.8	19.5	20.5	20.5	64	24	11	17.4	49

QHAVN-N series Switching type in-line

Metric specification

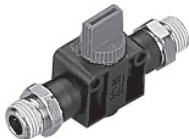

Thread size R1(PT)	Thread size R2(PT)	Model	A ₁	A ₂	B ₁	B ₂	E	L	ØP	F ₁	F ₂	Across flats H ₁	Across flats H ₂	Effective orifice mm ²	Weight (g)
1/8"	1/8"	QHAVN - N 01	6	6	17.4	41	73.2	67.2	16.5	18	8	19	19	5.5	64
1/4"	1/4"	QHAVN - N 02	9	9	21.2	41	80.2	19.5	16.5	18	8	19	19	15.8	68
3/8"	3/8"	QHAVN - N 03	9	9	21.2	41	80.2	19.5	16.5	18	8	19	19	15.7	72

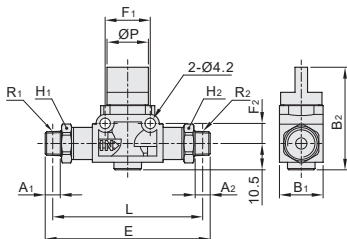

Inch specification

Thread size R1(NPT)	Thread size R2(NPT)	Model	A ₁	A ₂	B ₁	B ₂	E	L	ØP	F ₁	F ₂	Across flats H ₁	Across flats H ₂	Effective orifice mm ²	Weight (g)
1/8"	1/8"	QHAVN - N 1/8	6	6	17.4	41	73.2	67.2	16.5	18	8	19	19	5.5	64
1/4"	1/4"	QHAVN - N 1/4	9	9	21.2	41	80.2	19.5	16.5	18	8	19	19	15.8	68
3/8"	3/8"	QHAVN - N 3/8	9	9	21.2	41	80.2	19.5	16.5	18	8	19	19	15.7	72

QHV series Switching Type In-line

Dimensions

CHELIC

QHVN-R series Switching type in-line



Metric specification

Port size ØD	Thread size R(PT)	Model	A	B ₁	B ₂	C	E	L	ØP ₁	ØP ₂	F ₁	F ₂	Across flats H	Effective orifice mm ²	Weight (g)
Ø4	1/8"	QHVN-R 4 - 01	6	17.4	41	14.5	57.7	54.7	10.5	16.5	18	8	14	3.4	34
Ø6	1/8"	QHVN-R 6 - 01	6	17.4	41	16.5	57.4	54.4	12.4	16.5	18	8	14	7.5	35
	1/4"	QHVN-R 6 - 02	9	17.4	41	16.5	61	56.5	12.4	16.5	18	8	14	7.5	36
Ø8	1/8"	QHVN-R 8 - 01	6	17.4	41	18.5	63.6	60.6	15	16.5	18	8	19	8.6	46
	1/4"	QHVN-R 8 - 02	9	17.4	41	18.5	66.6	62.1	15	16.5	18	8	19	8.6	46
	3/8"	QHVN-R 8 - 03	9	17.4	41	18.5	66.6	62.1	15	16.5	18	8	19	8.6	49.5

Inch specification

Port size ØD	Thread size R(NPT)	Model	A	B ₁	B ₂	C	E	L	ØP ₁	ØP ₂	F ₁	F ₂	Across flats H	Effective orifice mm ²	Weight (g)
5/32"	1/8"	QHVN-R 5/32 - 01	6	17.4	41	14.5	57.7	54.7	10.5	16.5	18	8	14	3.4	34
1/4"	1/8"	QHVN-R 1/4 - 01	6	17.4	41	16.5	57.4	54.4	12.4	16.5	18	8	14	7.5	35
	1/4"	QHVN-R 1/4 - 02	9	17.4	41	16.5	61	56.5	12.4	16.5	18	8	14	7.5	36
5/16"	1/8"	QHVN-R 5/16 - 01	6	17.4	41	18.5	63.6	60.6	15	16.5	18	8	19	8.6	46
	1/4"	QHVN-R 5/16 - 02	9	17.4	41	18.5	66.6	62.1	15	16.5	18	8	19	8.6	46
	3/8"	QHVN-R 5/16 - 03	9	17.4	41	18.5	66.6	62.1	15	16.5	18	8	19	8.6	49.5

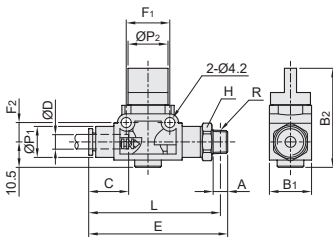

QHVN-L series Switching type in-line



Metric specification

Port size ØD	Thread size R(PT)	Model	A	B ₁	B ₂	C	E	L	ØP ₁	ØP ₂	F ₁	F ₂	Across flats H	Effective orifice mm ²	Weight (g)
Ø4	1/8"	QHVN-L 4 - 01	6	17.4	41	14.5	57.7	54.7	10.5	16.5	18	8	14	3.4	34
Ø6	1/8"	QHVN-L 6 - 01	6	17.4	41	16.5	57.4	54.4	12.4	16.5	18	8	14	7.5	35
	1/4"	QHVN-L 6 - 02	9	17.4	41	16.5	61	56.5	12.4	16.5	18	8	14	7.5	36
Ø8	1/8"	QHVN-L 8 - 01	6	17.4	41	18.5	63.6	60.6	15	16.5	18	8	19	8.6	46
	1/4"	QHVN-L 8 - 02	9	17.4	41	18.5	66.6	62.1	15	16.5	18	8	19	8.6	46
	3/8"	QHVN-L 8 - 03	9	17.4	41	18.5	66.6	62.1	15	16.5	18	8	19	8.6	49.5

Inch specification

Port size ØD	Thread size R(NPT)	Model	A	B ₁	B ₂	C	E	L	ØP ₁	ØP ₂	F ₁	F ₂	Across flats H	Effective orifice mm ²	Weight (g)
5/32"	1/8"	QHVN-L 5/32 - 01	6	17.4	41	14.5	57.7	54.7	10.5	16.5	18	8	14	3.4	34
1/4"	1/8"	QHVN-L 1/4 - 01	6	17.4	41	16.5	57.4	54.4	12.4	16.5	18	8	14	7.5	35
	1/4"	QHVN-L 1/4 - 02	9	17.4	41	16.5	61	56.5	12.4	16.5	18	8	14	7.5	36
5/16"	1/8"	QHVN-L 5/16 - 01	6	17.4	41	18.5	63.6	60.6	15	16.5	18	8	19	8.6	46
	1/4"	QHVN-L 5/16 - 02	9	17.4	41	18.5	66.6	62.1	15	16.5	18	8	19	8.6	46
	3/8"	QHVN-L 5/16 - 03	9	17.4	41	18.5	66.6	62.1	15	16.5	18	8	19	8.6	49.5

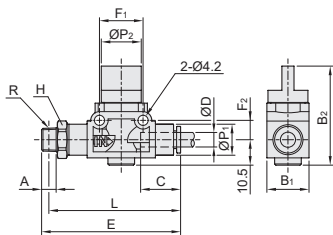

SQ

MSQ

SP

SQ J

SQR

SQ G

RQL

M

Stainless steel fitting

Brass Fitting

Full copper fitting

SC

QS

QMC

QT

QH

QV

QST

PU Tube

QHV3 series Switching Type In-line

Product features/ Code of order

CHELIC

Internal structure

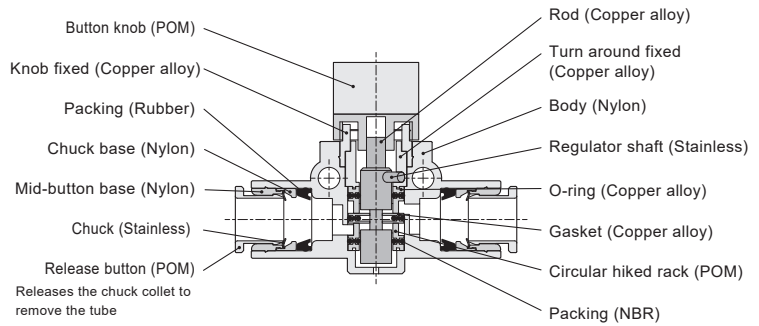

Specification

Item	Port size	Ø6, Ø8, Ø10, Ø12
Fluid		Air
Pressure range	kgf/cm ² (kPa)	0 ~ 9 (0 ~ 900)
Proof pressure	kgf/cm ² (kPa)	10 (1000)
Proof vacuum pressure	kPa(Torr)	-100 (10)
Ambient and fluid temperature	°C	5 ~ 60
Material	Body	Brass (Nickel-plated)
	Plastic	NYLON, PBT, PP
Thread	Rc(PT)	1/8", 1/4", 3/8"
Seal on the threads		With sealant

Code of order

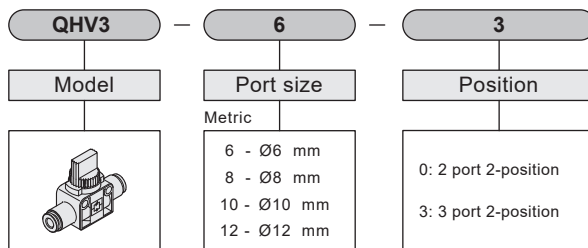

QHV3 series Switching Type In-line

Dimensions

CHELIC

QHV3 series Switching type in-line

Metric specification

Port size ØC	Port size ØD	Model	ØP	Ød	E	F	L	H	F ₁	M
Ø6	Ø6	QHV3 6-6	15	4.2	16.5	24	52	41	18	18
Ø8	Ø6	QHV3 8-6	15	4.2	16.5	24	52	41		18
Ø8	Ø8	QHV3 8-8	15	4.2	16.5	24	52	41		18
Ø10	Ø8	QHV3 10-8	21.5	4.2	21.5	29	63	45	24	22
Ø10	Ø10	QHV3 10-10	21.5	4.2	21.5	29	63	45		22
Ø12	Ø10	QHV3 12-10	21.5	4.2	21.5	29	63	45		22
Ø12	Ø12	QHV3 12-12	21.5	4.2	21.5	29	63	45		22

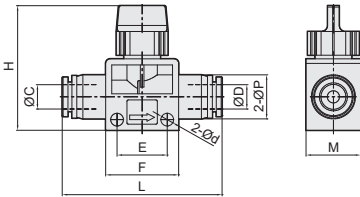

SQ

MSQ

SP

SQ J

SQR

SQ G

RQL

M

Stainless steel fitting

Brass Fitting

Full copper fitting

SC

QS

QMC

QT

QH

QV

QST

PU Tube

QVA series Ball Type Switch In-line

Product features/ Code of order

CHELIC

Internal structure

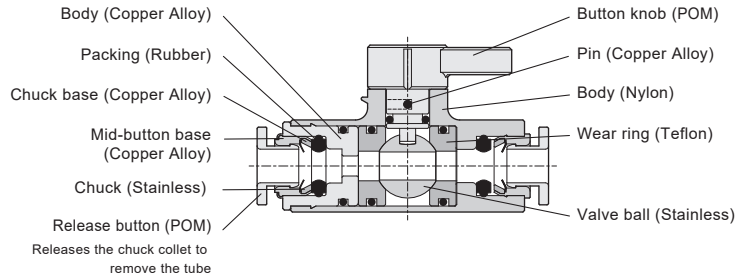

Specification

Item	Port size	Ø4, Ø6, Ø8, Ø10, Ø12, 5/32", 5/16", 3/8"
Fluid		Air
Pressure range	kgf/cm ² (kPa)	0 ~ 9 (0 ~ 900)
Proof pressure	kgf/cm ² (kPa)	10 (1000)
Proof vacuum pressure	kPa(Torr)	-100 (10)
Ambient and fluid temperature	°C	5 ~ 60
Material	Body	Brass (Nickel-plated)
	Plastic	NYLON, PBT, PP
Thread	Rc (PT/NPT)	M5x0.8p (10/32"), 1/8", 1/4", 3/8"
Seal on the threads		With sealant

Code of order

QVA — **6** —

Model	Port size	Thread
	Metric 4 - Ø4 mm 6 - Ø6 mm	Metric M5 - M5x0.8p 01 - PT 1/8"
	Inch 5/32" - Ø3.97 mm Inch 1/4" is not produce right now.	Inch 10/32 - 10/32" QVAB limited specification option.

Code of order

QVA — **8** —

Model	Port size	Thread
	Metric 8 - Ø8 mm 10 - Ø10 mm 12 - Ø12 mm	Metric 02 - PT 1/4" 03 - PT 3/8" 04 - PT 1/2"
	Inch 5/16" - Ø7.94 mm 3/8" - Ø9.53 mm Inch 1/4" is not produce right now.	Inch 01 - NPT 1/8" 02 - NPT 1/4" 03 - NPT 3/8" 04 - NPT 1/2" QVAB limited specification option.

QVA series Ball Type Switch In-line

Dimensions

CHELIC

QVA series Ball type switch in-line



Metric: Ø4, Ø6
Imperial: 5/32"



Metric: Ø8, Ø10, Ø12
Imperial: 5/16", 3/8"

Metric specification

Port size ØD	Model	A	B	C ₁	C ₂	E	F	ØG	J	L	Effective orifice mm ²	Weight (g)
Ø4	QVA 4 - 4	13	36.4	10.6	11.5	18.8	18.8	11.5	-	20.9	9.6	10
Ø6	QVA 6 - 6	13	37.1	11.6	11.8	19.2	18.8	11.5	-	20.9	9.6	15

Inch specification

Port size ØD	Model	A	B	C ₁	C ₂	E	F	ØG	J	L	Effective orifice mm ²	Weight (g)
5/32"	QVA 5/32 - 5/32	13	36.4	10.6	11.5	18.8	18.8	11.5	-	20.9	9.6	10

Metric specification

Port size ØD	Model	A	B	C ₁	C ₂	E	F	ØG	J	L	Effective orifice mm ²	Weight (g)
Ø8	QVA 8 - 8	18	46.8	16.7	16.7	22.7	26.5	17	36	27.7	19.6	25
Ø10	QVA 10 - 10	18	50.9	18.7	18.7	29.2	30	24	36	34	50.2	60
Ø12	QVA 12 - 2	18	61.5	21.2	19.8	31.6	30	24	36	34	50.2	55

Inch specification

Port size ØD	Model	A	B	C ₁	C ₂	E	F	ØG	J	L	Effective orifice mm ²	Weight (g)
5/16"	QVA 5/16 - 5/16	18	46.8	16.7	13.5	22.7	26.5	17	36	27.7	19.6	25
3/8"	QVA 3/8 - 3/8	18	50.9	18.7	18.3	29.2	30	24	36	34	50.2	60

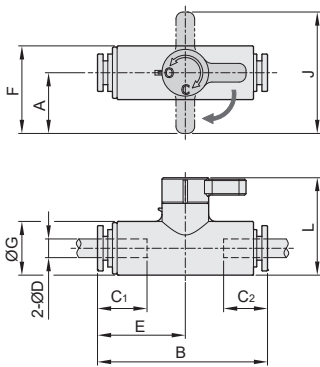

QVAH series Bulkhead switch in-line



Metric: Ø4, Ø6
Imperial: 5/32"



Metric: Ø8, Ø10, Ø12
Imperial: 5/16", 3/8"

Metric specification

Port size ØD	Thread size M	Model	A	B	C ₁	C ₂	E	F	ØG	J	K	L	Across flats H ₁	Across flats H ₂	Effective orifice mm ²	Weight (g)
Ø4	M12 x 1	QVAH 4 - 4	13	51.1	10.6	11.2	18.8	18.8	11.5	-	13.6	20.9	14	14	9.6	35
Ø6	M12 x 1	QVAH 6 - 6	13	51.8	11.6	11.6	19.2	18.8	11.5	-	13.9	20.9	14	14	9.6	47

Inch specification

Port size ØD	Thread size M	Model	A	B	C ₁	C ₂	E	F	ØG	J	K	L	Across flats H ₁	Across flats H ₂	Effective orifice mm ²	Weight (g)
5/32"	M12x1	QVAH 5/32-5/32	13	51.1	10.6	11.2	18.8	18.8	11.5	-	13.6	20.9	14	14	9.6	35

Metric specification

Port size ØD	Thread size M	Model	A	B	C ₁	C ₂	E	F	ØG	J	K	L	Across flats H ₁	Across flats H ₂	Effective orifice mm ²	Weight (g)
Ø8	M16x1	QVAH 8 - 8	18	67.7	16.6	18.6	22.7	26.5	17	36	20.2	27.7	19	19	19.6	60
Ø10	M20x1	QVAH 10 - 10	18	80.8	18.7	20.9	22.8	30	24	36	21	34	24	24	50.2	100
Ø12	M22x1	QVAH 12 - 12	18	84.4	19.2	23.7	31.6	30	24	36	22.2	34	24	24	50.2	110

Inch specification

Port size ØD	Thread size M	Model	A	B	C ₁	C ₂	E	F	ØG	J	K	L	Across flats H ₁	Across flats H ₂	Effective orifice mm ²	Weight (g)
5/16"	M16x1	QVAH 5/16-5/16	18	67.7	16.6	18.6	22.7	26.5	17	36	20.2	27.7	19	19	19.6	60
3/8"	M20x1	QVAH 3/8-3/8	18	80.8	18.7	20.9	22.8	30	24	36	21	34	24	24	50.2	100

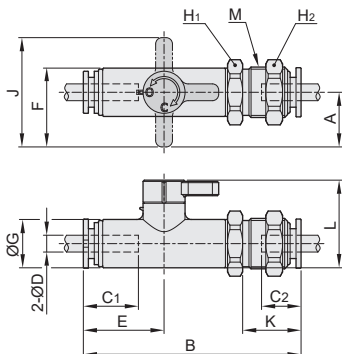

SQ □

MSQ □

SP □

SQ □ J

SQR □

SQ □ G

RQL

M □

Stainless steel fitting

Brass Fitting

Full copper fitting

□ SC

QS □

QMC

QT

QH □

QV □

QST

PU Tube

QVA series Ball Type Switch In-line

Dimensions

CHELIC

QVAB series Ball type switch male straight

Metric specification



Metric: Ø4, Ø6
Imperial: 5/32"

Port size ØD	Thread size M	Model	A	B	C	E	F	ØG	J	K	L	Across flats H	Effective orifice mm ²	Weight (g)
Ø4	M5	QVAB 4 - M5	13	42.4	10.6	18.8	18.8	11.5	—	4.1	20.9	12	9.6	12
	PT 1/8"	QVAB 4 - 01	13	44.9	10.6	18.8	18.8	11.5	—	6	20.9	12	9.6	13
Ø6	M5	QVAB 6 - M5	13	42.8	11.6	19.2	18.8	11.5	—	4.1	20.9	12	9.6	18
	PT 1/8"	QVAB 6 - 01	13	45.3	11.6	19.2	18.8	11.5	—	6	20.9	12	9.6	20

Inch specification



Metric: Ø8, Ø10, Ø12
Imperial: 5/16", 3/8"

Port size ØD	Thread size M	Model	A	B	C	E	F	ØG	J	K	L	Across flats H	Effective orifice mm ²	Weight (g)
5/32"	NPT 10/32	QVAB 5/32-10/32	13	42.4	10.6	18.8	18.8	11.5	—	4.1	20.9	12	9.6	12
	NPT 1/8"	QVAB 5/32 - 01	13	44.9	10.6	18.8	18.8	11.5	—	6	20.9	12	9.6	13

Metric specification

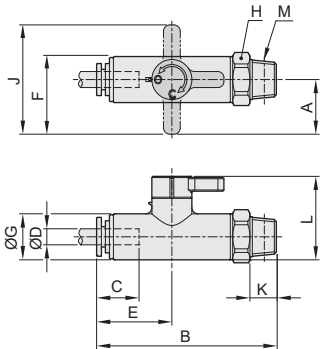

Port size ØD	Thread size M	Model	A	B	C	E	F	ØG	J	K	L	Across flats H	Effective orifice mm ²	Weight (g)
Ø8	PT 1/8"	QVAB 8 - 01	18	55	16.6	22.7	26.5	17	36	6	27.7	19	19.6	42
	PT 1/4"	QVAB 8 - 02	18	58	16.6	22.7	26.5	17	36	9	27.7	19	19.6	45
	PT 3/8"	QVAB 8 - 03	18	58	16.6	22.7	26.5	17	36	9	27.7	19	19.6	50
Ø10	PT 1/4"	QVAB 10 - 02	18	69.6	18.7	22.8	30	24	36	9	34	24	50.2	91
	PT 3/8"	QVAB 10 - 03	18	69.6	18.7	22.8	30	24	36	9	34	24	50.2	95
	PT 1/2"	QVAB 10 - 04	18	71.6	18.7	22.8	30	24	36	11	34	24	50.2	99
Ø12	PT 1/4"	QVAB 12 - 02	18	71.6	19.2	31.6	30	24	36	9	34	24	50.2	90
	PT 3/8"	QVAB 12 - 03	18	71.6	19.2	31.6	30	24	36	9	34	24	50.2	95
	PT 1/2"	QVAB 12 - 04	18	73.6	19.2	31.6	30	24	36	11	34	24	50.2	100

Inch specification

Port size ØD	Thread size M	Model	A	B	C	E	F	ØG	J	K	L	Across flats H	Effective orifice mm ²	Weight (g)
5/16"	NPT 1/8"	QVAB 5/16 - 01	18	55	16.6	22.7	26.5	17	36	6	27.7	19	19.6	42
	NPT 1/4"	QVAB 5/16 - 02	18	58	16.6	22.7	26.5	17	36	9	27.7	19	19.6	45
	NPT 3/8"	QVAB 5/16 - 03	18	58	16.6	22.7	26.5	17	36	9	27.7	19	19.6	50
3/8"	NPT 1/4"	QVAB 3/8 - 02	18	69.6	18.7	22.8	30	24	36	9	34	24	50.2	91
	NPT 3/8"	QVAB 3/8 - 03	18	69.6	18.7	22.8	30	24	36	9	34	24	50.2	95
	NPT 1/2"	QVAB 3/8 - 04	18	71.6	18.7	22.8	30	24	36	11	34	24	50.2	99

QST series Speed Controller - Panel Type

Product features/ Code of order

CHELIC

Code of order



QST	—	6	—	6
Model		Port size		Port size
	Metric	4 - Ø4 mm	Metric	4 - Ø4 mm
		6 - Ø6 mm		6 - Ø6 mm
		8 - Ø8 mm		8 - Ø8 mm
		10 - Ø10 mm		10 - Ø10 mm
Inch	5/32" - Ø3.97 mm	Inch	5/32" - Ø3.97 mm	
	1/4" - Ø6.35 mm		1/4" - Ø6.35 mm	
	5/16" - Ø7.94 mm		5/16" - Ø7.94 mm	
	3/8" - Ø9.53 mm		3/8" - Ø9.53 mm	

QST:
Speed controller -
Panel type

Specification

Item	Port size	Ø4, Ø6, Ø8, Ø10, 5/32", 1/4", 5/16", 3/8"
Fluid		Air
Pressure range	kgf/cm ² (kPa)	0 ~ 9 (900)
Proof pressure	kgf/cm ² (kPa)	10 (1000)
Number of needle rotation		10 (8) round
Ambient and fluid temperature	°C	5 ~ 60
Material	Body	Brass (Nickel-plated)
	Plastic	NYLON, PBT, PP

QST series Speed controller - Panel type

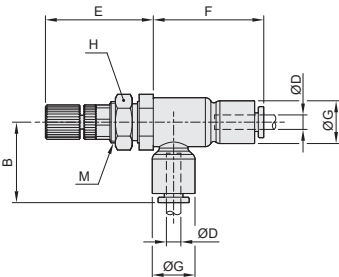

Metric specification

Port size ØD	Thread size ØD	Model	B	E	F	ØG	M	Across flats H	Effective orifice mm ²	Weight (g)
Ø4	Ø4	QST 4 - 4	23.4	31.3	32.1	12.4	M12x1.0p	14	3.4	35
Ø6	Ø6	QST 6 - 6	23.7	31.3	32.4	12.4	M12x1.0p	14	7.2	35
Ø8	Ø8	QST 8 - 8	29.5	36.5	37.6	17.8	M14x1.0p	17	8.7	70
Ø10	Ø10	QST 10 - 10	30.1	36.5	38.2	17.8	M14x1.0p	17	17.4	75

Inch specification

Port size ØD	Thread size ØD	Model	B	E	F	ØG	M	Across flats H	Effective orifice mm ²	Weight (g)
5/32"	5/32"	QST 5/32 - 5/32	23.4	31.3	32.1	12.4	M12x1.0p	14	3.4	35
1/4"	1/4"	QST 1/4 - 1/4	23.7	31.3	32.4	12.4	M12x1.0p	14	7.2	35
5/16"	5/16"	QST 5/16 - 5/16	29.5	36.5	37.6	17.8	M14x1.0p	17	8.7	70
3/8"	3/8"	QST 3/8 - 3/8	30.1	36.5	38.2	17.8	M14x1.0p	17	17.4	75

SQ

MSQ

SP

SQ J

SQR

SQ G

RQL

M

Stainless
steel fitting

Brass
Fitting

Full copper
fitting

SC

QS

QMC

QT

QH

QV

QST

PU Tube