

PRUT2 series Mechanically Jointed Rodless Cylinder (Precision linear guide)

Product feature

CHELIC

Feature

- Precision adjustable pneumatic cushion to absorb the impact of inertia
- Stroke length is able to customized
- With precision linear slides can carry larger loading

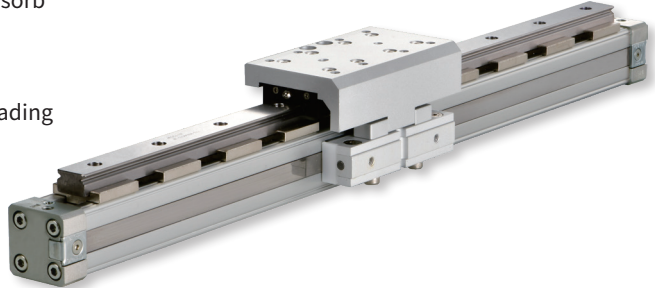

Specification

Item	Bore size (mm)	Ø16	Ø20	Ø25	Ø32	Ø40
Action		Double acting				
Fluid		Air				
Pressure range	kgf/cm ² (kPa)	2~7(200~700)	1.5 ~ 7 (150 ~ 700)			
Max. operating pressure	kgf/cm ² (kPa)	8 (800)				
Ambient and fluid temperature	°C	0 ~ 60				
Piston speed	mm/s	50 ~ 500				
Lubrication		Lubrication free type				
Cushion		Air cushion				
Port size		M5	G1/8		G1/4	
Sensing device		With magnet				

Standard stroke

Bore size (mm)	Standard stroke (mm)
Ø16	50 ~ 1000
Ø20	50 ~ 1000
Ø25	50 ~ 1500
Ø32	50 ~ 1500
Ø40	50 ~ 1500

Theoretical output

Unit: kgf

Bore size (mm)	Operating	Piston area (cm ²)	Air pressure (kgf / cm ²)						
			1	2	3	4	5	6	7
Ø16	Push	2.0	—	4	6	8	10	12	14
Ø20	Push	3.1	—	6.2	9.4	12.5	15.7	18.8	21.9
Ø25	Push	4.9	—	9	14	19	24	29	34
Ø32	Push	8.0	—	16	24	32	40	48	56
Ø40	Push	12.5	—	25	37.5	50	62.5	75	87.5

 Note: All of above are theoretical data. Before actual adoption, the frictional resistance and mechanical efficiency shall be taken into consideration (about 70% ~ 80%)

PRUT2 series Mechanically Jointed Rodless Cylinder (Precision linear guide)

Code of order

CHELIC

Code of order **PRUT2 16 x 200 – L – AM2 – 95 2**



1

Mark	Bore size (mm)
16	Ø16
20	Ø20
25	Ø25
32	Ø32
40	Ø40

2

Bore size	Stroke (mm)
Ø16	50 ~ 1000
Ø20	
Ø25	50 ~ 1500
Ø32	
Ø40	

● Any strock available within above length with 1 mm as minimum.

3

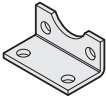
Mark	Bracket
None	Without bracket
L	

4

Mark	Cushion option	Cushion
None	Without cushion	A : Shock absorber M : Air cushioning base
AM1	Left side with shock absorber	
AM2	Both sides with shock absorbers	
AM3	Right side with shock absorber	

● How to select Shock absorber

Bore size (mm)	Shock absorber model	Maximum absorption (N · m)
16	SAT-1007C	6
20	SAT-1007C	6
25	SAT-1210C	12
32	SAT-1412C	20
40	SAT-2015C	59

5

Mark	Sensor switch
None	Without sensor switch
95	CS-95

● Image

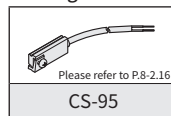

6

Mark	Sensor quantity
1	1 pc
2	2 pcs

PRE

PRET(P)

PRU(F)2

PRUT2

MRD

MRB

MRBT

MRX

MRU

MRH

MRY

PRUT2 series Mechanically Jointed Rodless Cylinder (Precision linear guide)

Product feature

CHELIC

Internal structure

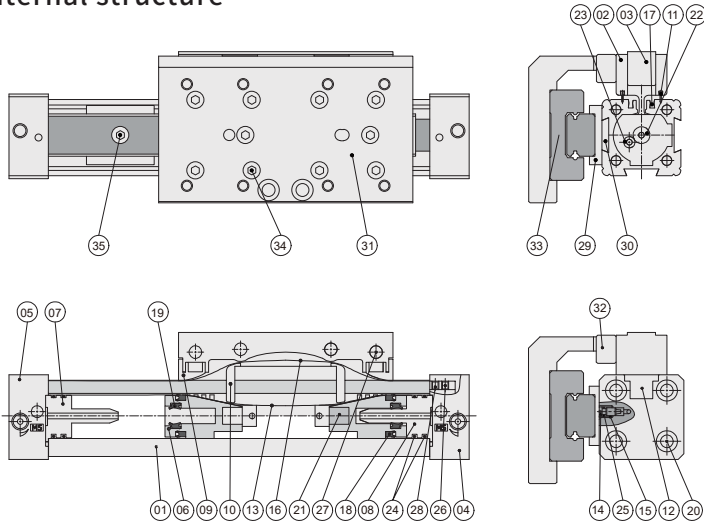

Product weight

Unit: kg

Bore size(mm)	Stroke = 0mm	Additional weight
Ø16	0.37	0.24
Ø20	0.86	0.39
Ø25	1.16	0.44
Ø32	2.24	0.69
Ø40	2.92	0.81

Note: Additional weight per each 100 mm in $\pm 5\%$ difference

Components and material list

NO.	Item	Material	NO.	Item	Material
01	Body	Aluminum alloy	19	Air cushion packing	NBR
02	Slider	Aluminum alloy	20	End cap screw	Carbon steel
03	Slider cap	Aluminum alloy	21	Piston magnet	Alloy steel
04	Left end cap	Aluminum alloy	22	End cap O-ring	NBR
05	Right end cap	Aluminum alloy	23	Air cushion pin O-ring_1	NBR
06	Piston	POM	24	Air cushion pin O-ring_2	NBR
07	Air cushion lever (left)	POM	25	Air cushion pin O-ring	NBR
08	Air cushion lever (right)	POM	26	Cap screw	Carbon steel
09	Outer belt block	POM	27	Slider plate screw	Carbon steel
10	Belt guide block	POM	28	Inner belt screw	Carbon steel
11	Slider plate	NBR	29	Slider bracket	Carbon steel
12	Cover	POM	30	Slider block	Carbon steel
13	Inner belt	TPU	31	Rail slider	Carbon steel
14	Air cushion pin	Copper Alloy	32	Rail slider block	Carbon steel
15	Bush	Stainless steel	33	Rail	Carbon steel
16	Outer belt	Stainless steel	34	Hexagon socket head cap screw	Alloy steel
17	Magnet belt	Rubber magnet	35	Hexagon socket head cap screw	Alloy steel
18	Piston packing	NBR			

Mounting type

● Mounting bracket type

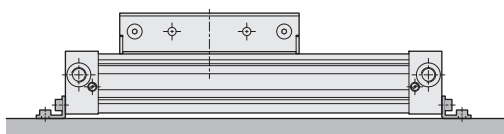

● Mounting cover type

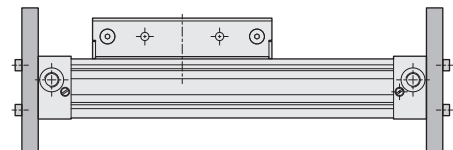

Note: The two end embedded with thread holes to apply screw directly, thus the screw can't be used.

PRUT2 series Mechanically Jointed Rodless Cylinder (Precision linear guide)

Installation

CHELIC

Load and moment allowable

The maximum allowable moment is to calculate the piston of center of gravity. In general situation, the moment of load can not exceed the allowable range. If the moment of load is not single direction, its value can not bigger than 1.

$$M_x = F_p \times R_1 \quad M_y = F_p \times R_2 \quad M_z = F_p \times R_1$$

$$\frac{M_x}{M_{x \max}} + \frac{M_y}{M_{y \max}} + \frac{M_z}{M_{z \max}} + \frac{F_p}{F_{p \max}} + \frac{F_y}{F_{y \max}} \leq 1$$

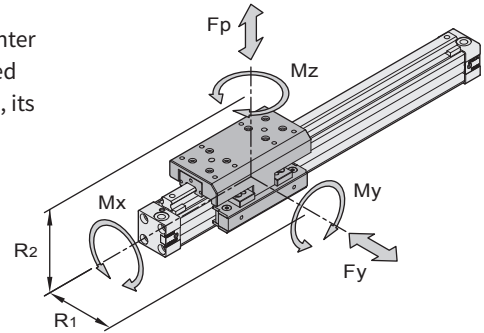

PRE

PRET(P)

PRU(F)2

PRUT2

Model	Bore size (mm)	Stroke (mm)	Theoretical force in 6 bar (N)	Max. load (N)		Max. Moment allowable (Nm)		
				Fp	Fy	Mz	Mx	My
	16	50~1000	121	500	500	16	15	16
	20	50~1000	189	1000	1000	90	35	90
	25	50~1500	294	1500	1500	100	50	100
	32	50~1500	482	3000	3000	200	100	200
	40	50~1500	754	4000	4000	200	140	200

MRD

MRB

MRBT

MRX

MRU

MRH

MRY

Load weight and piston speed

The shock absorbing device at end of cylinder is adjustable for preventing damage from huge impact. The shock absorber shall be applied before the cylinder produce high movements.

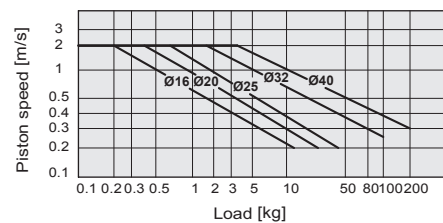

Load weight and stroke length

The long stroke cylinder may curve when load weight increased. The support bracket shall be considered to apply at the middle of stroke for preventing deforming.

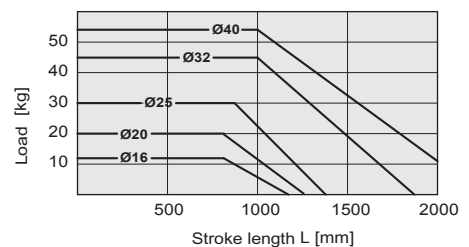
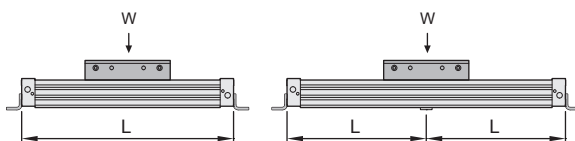

PRUT2 series Mechanically Jointed Rodless Cylinder (Precision linear guide)

Dimensions

CHELIC

PRUT2 Ø16 ~ Ø40

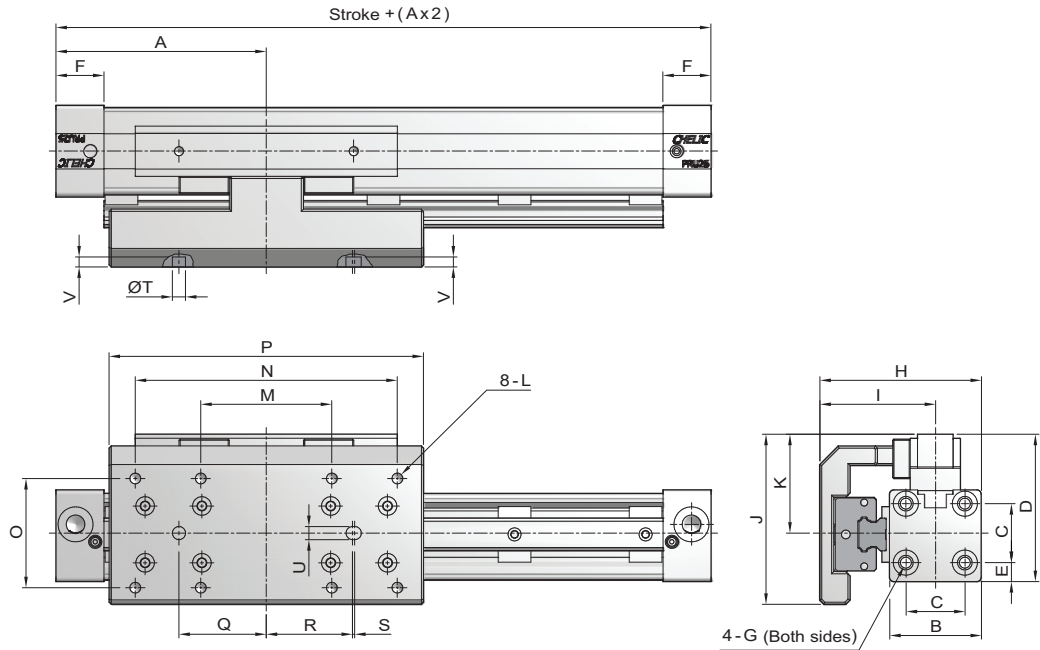

Unit: mm

Mark Bore size	A	B	C	D	E	F	G	H	I	J	K	L	M	N	O	P	Q	R	S	T	U	V
Ø16	65	30	18	45	6.4	14	M3×0.5P×9dp	55	40	53.6	29.6	M4×0.7P×8dp	30	70	36	90	20	19.5	1	4	4	3
Ø20	80	37	24	55	6	22	M4×0.7P×12dp	69	50.5	66	37	M5×0.8P×10dp	35	85	45	120	30	29.5	1	4	4	3
Ø25	100	42	27	67.5	8.7	22	M5×0.8P×15dp	74	53	77.9	45.3	M6×1P×12dp	60	120	50	144	40	39.5	1	5	5	3
Ø32	125	54	36	88.3	9.5	25.5	M6×1P×15dp	89	62	103.1	61.1	M6×1P×12dp	80	160	64	184	40	39.5	1	6	6	4
Ø40	150	69	54	95.5	7.5	28	M6×1P×15dp	106.5	72	108	61	M6×1P×12dp	100	200	78	226	50	49.5	1	6	6	4

Shock absorber assembly and dimension

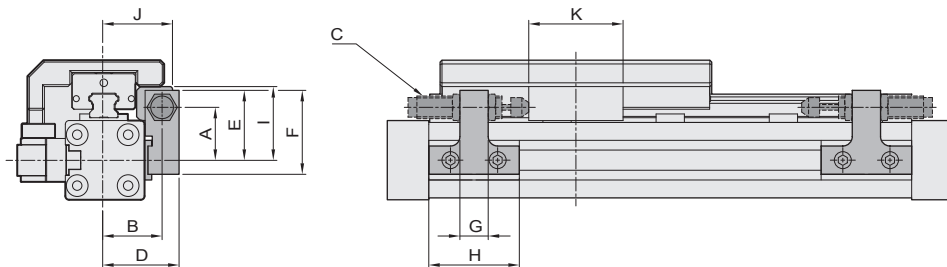

How to select Shock absorber

Unit: mm

Mark Bore size	A	B	C	D	E	F	G	H	I	J	K
Ø16	21.5	24.4	M10x1.0P	31.9	29	36.5	12	48	30	30	25
Ø20	26	26	M10x1.0P	34	35	42.5	15	48	36.5	32	25
Ø25	28	31.5	M12x1.0P	40.5	37	44.5	15	48	39	37	50
Ø32	35	36.5	M14x1.5P	46.5	45	52.5	15	48	48	42	50
Ø40	42	50	M20x1.5P	64	56	66	20	48	58.5	58	60

Bore size (mm)	Shock absorber list	Maximum absorption (N · m)
Ø16	SAT-1007C	6
Ø20	SAT-1007C	6
Ø25	SAT-1210C	12
Ø32	SAT-1412C	20
Ø40	SAT-2015C	59

PRUT2 series Mechanically Jointed Rodless Cylinder (Precision linear guide)

Mounting type and operation of sensor switch

CHELIC

■ Sensor switch mounting type

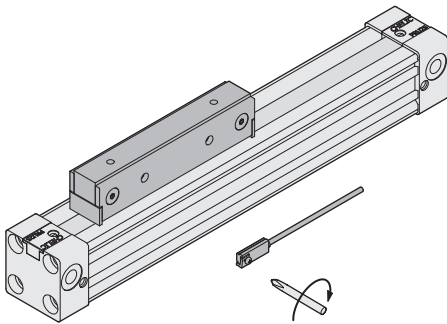

■ Sensor switch installation

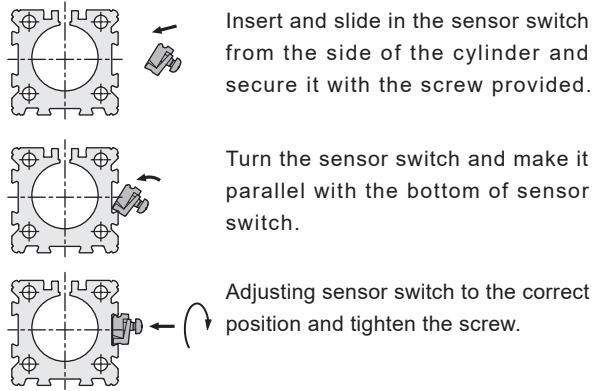

■ Operating range

When piston head moves the switch setting and adjustment will be based on the responding range generated by the magnetic field and the switch. (Please refer to the below table)

Unit: mm

Model	CS - 95	
Bore size	Operating range(F)	Hysteresis(R)
Ø16	10	1
Ø20	9	1.2
Ø25	9	1.2
Ø32	13	1.2
Ø40	10.5	1.5

■ Sensor switch setting and operating range

Sensor switch is fixed on the cylinder body. The magnetic piston head will activate the Sensor switch when it enters the operating range. It has 0.5mm differential.

▶ Sensor switch setting and operating range

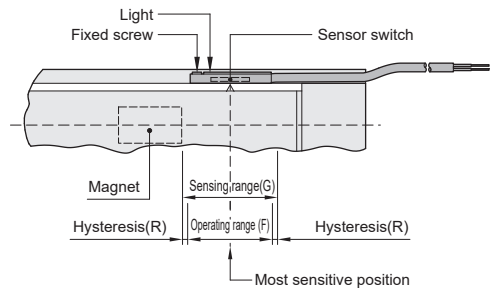

▶ Sensor switch introduction

CS-95

Voltage: DC 5 ~ 120V
AC 5 ~ 120V

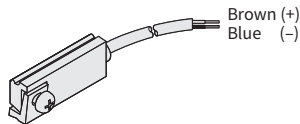

■ Multiple using example

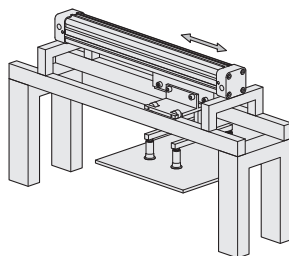

● Horizontal mounting

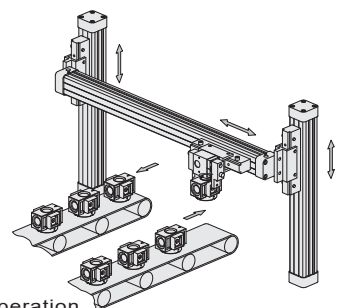

● Moving operation

PRE

PRET(P)

PRU(F)2

PRUT2

MRD

MRB

MRBT

MRX

MRU

MRH

MRY