

Vacuum pad

PAW/PA/PB/PC

Applicable

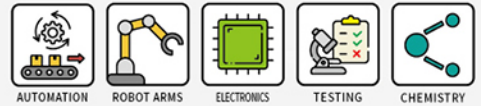

Various size. Various Materials. Optional brackets

Vacuum pad

Photos				
Series	PAW Series	PA Series	PB Series	PC Series
Styles	Oval pad	Single-layer type vacuum pad	Double-layer type vacuum pad	Three-layer type vacuum pad
Usage	Oval-shaped design allows the stable long workpieces during transportation.	Single-layer design allows the stable workpiece surfaces with flat and non-inclined surfaces.	The air inlet direction is optional with single centralized.	The flexible three-section bellows structure allows inclined or spherical workpieces.
Bracket	F: Vertical piping type K: Vertical piping with joint T: Lateral piping FS: Vertical spring type TS: Lateral spring type			
Pad diameters	2x4、3.5x7、4x10、4x20、4x30、5x10、5x20、5x30、6x10、6x20、6x30、8x20、8x30	Ø2、Ø3.5、Ø5、Ø6、Ø8、Ø10、Ø15、Ø20、Ø25、Ø30、Ø35、Ø40、Ø50、Ø60、Ø80、Ø100、Ø120、Ø150、Ø200	Ø6、Ø8、Ø10、Ø15、Ø20、Ø30、Ø40、Ø50、Ø60、Ø80	Ø5、Ø7、Ø10、Ø15、Ø20、Ø30、Ø40、Ø60
Material	N:NBR(rubber) U: PU(Uret-hane) S: Silicone, silicone rubber SE: Antistatic rubber E: Low-impedance antistatic rubber		N:NBR(rubber) S: Silicone, silicone rubber SE: Antistatic rubber	
Characteristics	<ul style="list-style-type: none"> The oblong shape allows to suctioning narrow-long workpieces and certain restricted spaces. Diversity: Various sizes, materials, and bracket options. Convenience: The structure is simple and compact, and can be easily replaced. 		<ul style="list-style-type: none"> Diversity: Various sizes, materials, and bracket options. Durability: Made of extremely oil-resistant rubber with long life and high strength. 	

This product series is designed for applications in industrial IoT systems.



PA□ series 1-Stage Vacuum Pad

Product features

CHELIC

Feature

- Single layer, suitable for smooth surface.
- Diversification: Various sizes, materials and brackets can be selected.
- Durability: Rubber with extremely high oil resistance material, long lifetime and high strength.



Vacuum pad material

Mark	Vacuum pad material	Hardness (HS)	Ambient and fluid temperature	Color	Electrical resistance(Note)
N	NBR(Rubber)	A60/S	-26~120°C	Black	-
U	PU(Uret-hane)	A60/S	-20~75°C	Black	-
S	Silicon, Silicone rubber	A60/S	-20~180°C	White	-
SE	Anti-static rubber	A60/S	-20~180°C	Black	10 ⁴ ~10 ⁶ Ω • cm
E	Low resistance & anti-static rubber	A70/S	-20~180°C	Black	200 Ω • cm

Note: The above value covers only general characteristics of subject rubber materials. Pad materials used by CHELIC pass internal standard.

Vacuum control system

Theoretical suction is calculated from pad size and vacuum value, which is only a number for reference. Theoretical suction is a number under static status. Please reserve enough margin while adding workpieces and movement.

Before confirm the Qty and location of suction pad, please reserve enough margin.

● Suction type

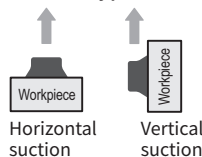

● Calculation formula

$$W = \frac{P \times A}{-10}$$

W: Force N

P : Vacuum pressure kPa

A : Pad area dimensions c²

Theoretical suction

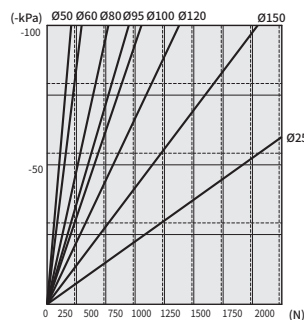
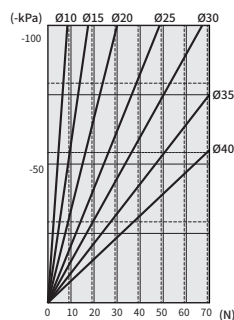

PA
真空吸盤
單層型

PB
真空吸盤
雙層型

PC
真空吸盤
三層型

PAG
薄型吸盤

PAO
防滑吸盤

PAP
平板型吸盤

PAQ
無痕型吸盤

PAW
橢圓型吸盤

PAL
不迴轉
真空吸盤

PBL
不迴轉
真空吸盤

PCL
不迴轉
真空吸盤

PAR
擺動
支架組

PS
非接觸式
吸盤

VP
真空
防脫落閥

PA□ series 1-Stage Vacuum Pad

Code of order

CHELIC

Code of order **PAFS 10 x 4 N - R**



1	Bracket	Vertical entry	Vertical entry with fitting	Side entry	Vertical entry with spring	Side entry with spring
	Mark	F	K	T	FS	TS
	Image					

2	Mark	02	3.5	05	06	08	10	15	20	25	30
	Pad dia. (mm)	Ø2	Ø3.5	Ø5	Ø6	Ø8	Ø10	Ø15	Ø20	Ø25	Ø30
	Mark	35	40	50	60	80	100	120	150	200	
	Pad dia. (mm)	Ø35	Ø40	Ø50	Ø60	Ø80	Ø100	Ø120	Ø150	Ø200	

3 ● Only available to FS, TS series

Mark	Stroke (mm)	Outer diameter (mm)	Mark	Stroke (mm)	Outer diameter (mm)
2.5	2.5	Ø2, Ø3.5	4	4	Ø10, Ø15
5	5		10	10	
Mark	Stroke (mm)	Outer diameter (mm)	Mark	Stroke (mm)	Outer diameter (mm)
3	3	Ø5, Ø6, Ø8	6	6	Ø20, Ø25, Ø30 Ø35, Ø40, Ø50
10	10		15	15	

● Only available to TS series

Mark	Stroke (mm)	Outer diameter (mm)	Mark	Stroke (mm)	Outer diameter (mm)
10	10	Ø60, Ø80	30	30	Ø120, Ø150, Ø200
30	30				
Mark	Stroke (mm)	Outer diameter (mm)			
15	15	Ø100			
30	30				

4	Mark	Vacuum pad material	Hardness (HS)	Ambient and fluid temperature	Color	Electrical resistance(Note)
	N	NBR(Rubber)	A60/S	-26~120°C	Black	-
	U	PU (Urethane)	A60/S	-20~75°C	Black	-
	S	Silicon, Silicone rubber	A60/S	-20~180°C	White	-
	SE	Anti-static rubber	A60/S	-20~180°C	Black	10 ⁴ ~10 ⁶ Ω • cm
	E	Low resistance & anti-static rubber	A70/S	-20~180°C	Black	200 Ω • cm

● Note: The above value covers only general characteristics of subject rubber materials. Pad materials used by CHELIC pass internal standard.

5	With ball joint type		
Mark	Outer diameter (mm)		
05	Ø5, Ø6, Ø8, Ø10, Ø15		
20	Ø20, Ø25, Ø30, Ø35, Ø40, Ø50		
60	Ø60, Ø80		

● Note: According to vacuum pad specification to py proper free holder.

● Note :Please refer to P.3-2.109

PA□ series 1-Stage Vacuum Pad

Optional correspondence table

CHELIC

PA series selection table:

Pad type	① Bracket					② Outer diameter	③ Stroke	④ Vacuum pad material					⑤ Ball joint type						
	F	K	T	FS	TS			N	U	S	SE	E	05	20	60				
PA	●		●	●	●	02	2.5 • 5	●		●	●	●							
	●		●	●	●	3.5		●		●	●	●							
	●		●	●	●	05	3 • 10	●		●	●	●	●						
	●		●	●	●	06		●	●	●	●	●	●						
	●		●	●	●	08		●	●	●	●	●	●						
	●	●	●	●	●	10	4 • 10	●	●	●	●	●	●	●					
	●	●	●	●	●	15		●	●	●	●	●	●						
	●	●	●	●	●	20	6 • 15	●	●	●	●	●	●		●				
	●	●	●	●	●	25		●	●	●	●	●	●		●				
	●	●	●	●	●	30		●	●	●	●	●	●		●				
	●	●	●	●	●	35		●	●	●	●	●	●		●				
	●	●	●	●	●	40		●	●	●	●	●	●		●				
	●	●	●	●	●	50		●	●	●	●	●	●		●				
	●	●	●		●	60	10 • 30	●	●	●	●	●					●		
	●	●	●		●	80		●		●								●	
	●		●		●	100	15 • 30	●		●	●	●							
			●		●	120		●		●									
			●		●	150		●		●									
		●		●	200	●			●										
						30		●		●									

PA
真空吸盤
單層型

PB
真空吸盤
雙層型

PC
真空吸盤
三層型

PAG
薄型吸盤

PAO
防滑吸盤

PAP
平板型吸盤

PAQ
無痕型吸盤

PAW
橢圓型吸盤

PAL
不迴轉
真空吸盤

PBL
不迴轉
真空吸盤

PCL
不迴轉
真空吸盤

PAR
擺動
支架組

PS
非接觸式
吸盤

VP
真空
防脫落閥

Product weight

Model	Weight(g)	Model	Weight(g)	Model	Weight(g)
2	0.02	20	1.37	80	52.26
3.5	0.03	25	2.44	100	144.5
5	0.15	30	2.96	120	158.1
6	0.18	35	6.11	150	294.5
8	0.24	40	6.95	200	541.4
10	0.31	50	8.31		
15	0.51	60	24.01		

PA□ series 1-Stage Vacuum Pad

Dimensions-PA series/ Standard type

CHELIC

External dimensions

● PA-02

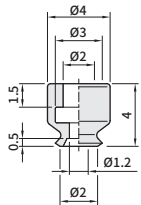

● PA-3.5

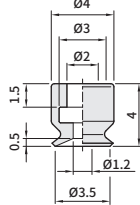

● PA-05

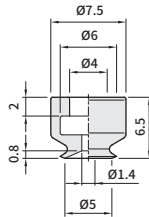

● PA-06

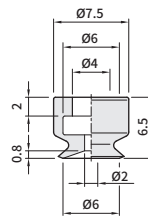

● PA-08

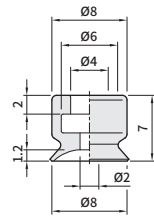

● PA-10

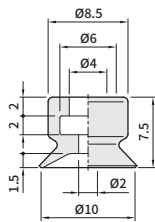

● PA-15

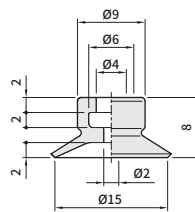

● PA-20

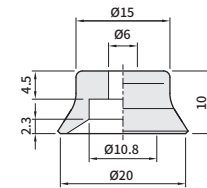

● PA-25

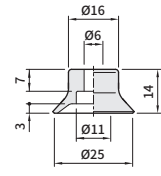

● PA-30

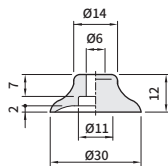

● PA-35

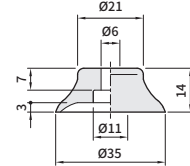

● PA-40

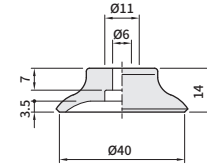

● PA-50

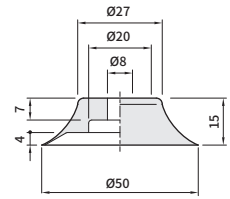

● PA-60

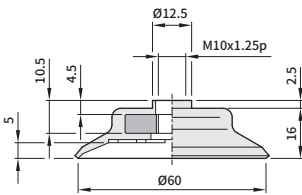

● PA-80

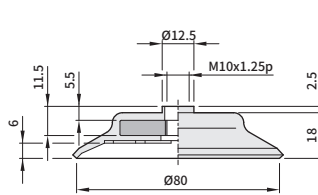

● PA-100

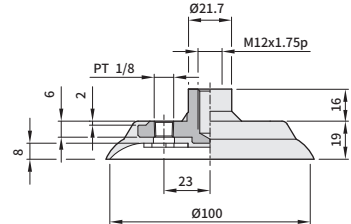

● PA-120

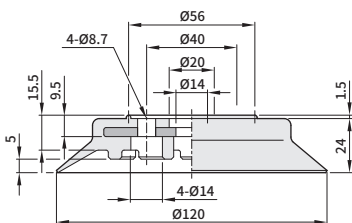

● PA-150

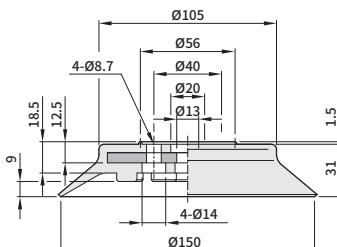

● PA-200

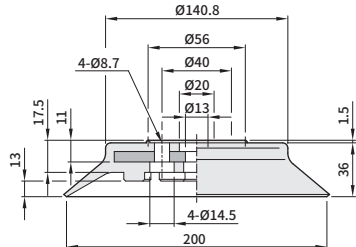

PA□ series 1-Stage Vacuum Pad

Dimensions-PAF series/ Vertical entry

CHELIC

Ø2 ~ Ø3.5

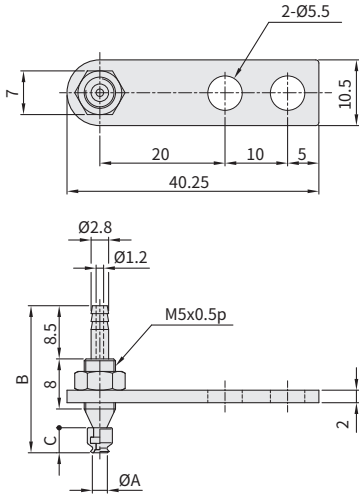

Unit: mm

Pad type	Model	Pad dia. A	Whole length B	C	Size of PU tube
Circle pad	PAF-02	Ø2	20.8	4	PU tube Ø4 x Ø2.5
	PAF-3.5	Ø3.5	23.5	4	

Ø5 ~ Ø8

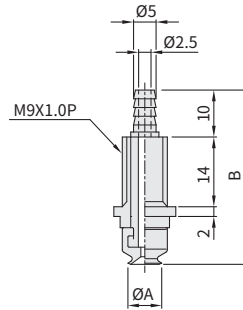

Unit: mm

Pad type	Model	Pad dia. A	Whole length B	Size of PU tube
Circle pad	PAF-05	Ø5	30.5	PU tube Ø6 x Ø4
	PAF-06	Ø6	31	
	PAF-08	Ø8	31	

Ø10 ~ Ø15

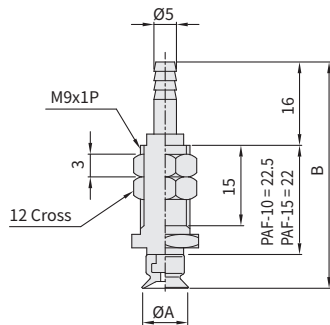

Unit: mm

Pad type	Model	Pad dia. A	Whole length B	Size of PU tube
Circle pad	PAF-10	Ø10	46	PU tube Ø6 x Ø4
	PAF-15	Ø15	46	

Ø20 ~ Ø50

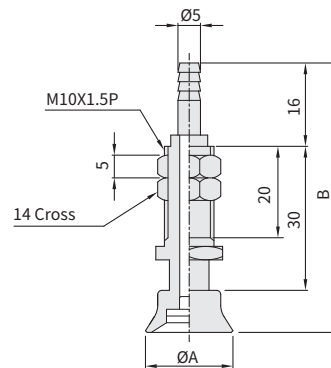

Unit: mm

Pad type	Model	Pad dia. A	Whole length B	Size of PU tube
Circle pad	PAF-20	Ø20	56	PU tube Ø6 x Ø4
	PAF-25	Ø25	60	
	PAF-30	Ø30	58	
	PAF-35	Ø35	60	
	PAF-40	Ø40	60	
	PAF-50	Ø50	61	

PA
真空吸盤
單層型

PB
真空吸盤
雙層型

PC
真空吸盤
三層型

PAG
薄型吸盤

PAO
防滑吸盤

PAP
平板型吸盤

PAQ
無痕型吸盤

PAW
橢圓型吸盤

PAL
不迴轉
真空吸盤

PBL
不迴轉
真空吸盤

PCL
不迴轉
真空吸盤

PAR
擺動
支架組

PS
非接觸式
吸盤

VP
真空
防脫落閥

PA□ series 1-Stage Vacuum Pad

Dimensions-PAF series/ Vertical entry

CHELIC

Ø60 ~ Ø80

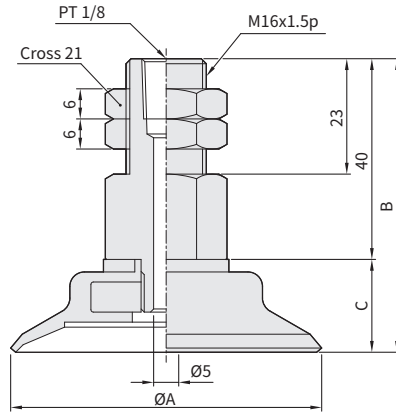

Unit: mm

Pad type	Model	Pad dia. A	Whole length B	C	Size of PU tube
Circle pad	PAF-60	Ø60	58.5	18.5	PT 1/8
	PAF-80	Ø80	60.5	20.5	

Ø100

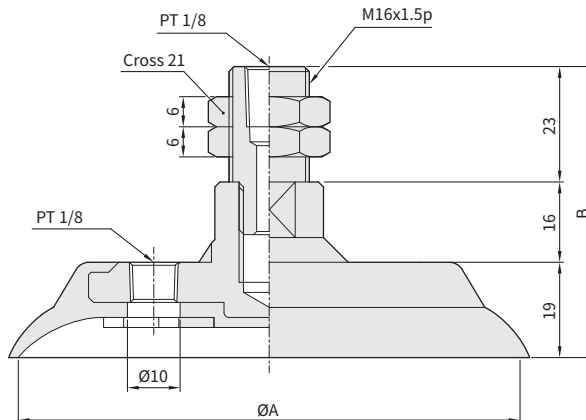

Unit: mm

Pad type	Model	Pad dia. A	Whole length B	Size of joint
Circle pad	PAF-100	Ø100	58	PT 1/8

PA□ series 1-Stage Vacuum Pad

Dimensions-PAK series/ Vertical entry with fitting

CHELIC

Ø10 ~ Ø15

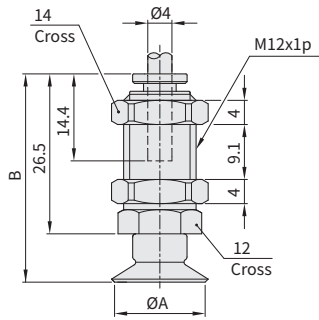

Unit: mm

Pad type	Model	Pad dia. A	Whole length B	Size of PU tube
Circle pad	PAK-10	Ø10	34	PU tube Ø4xØ2.5
	PAK-15	Ø15	34.5	

Ø20 ~ Ø35

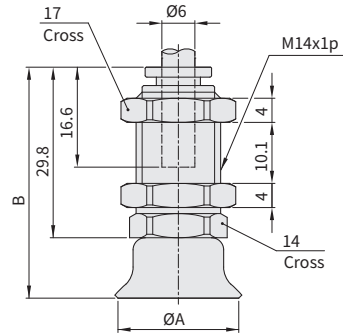

Unit: mm

Pad type	Model	Pad dia. A	Whole length B	Size of PU tube
Circle pad	PAK-20	Ø20	38.3	PU tube Ø6xØ4
	PAK-25	Ø25	42.3	
	PAK-30	Ø30	40.3	
	PAK-35	Ø35	42.3	

Ø40 ~ Ø50

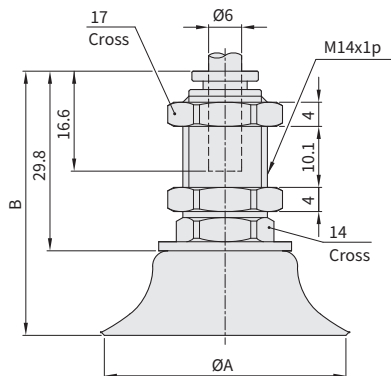

Unit: mm

Pad type	Model	Pad dia. A	Whole length B	Size of PU tube
Circle pad	PAK-40	Ø40	43.8	PU tube Ø6xØ4
	PAK-50	Ø50	44.8	

Ø60 ~ Ø80

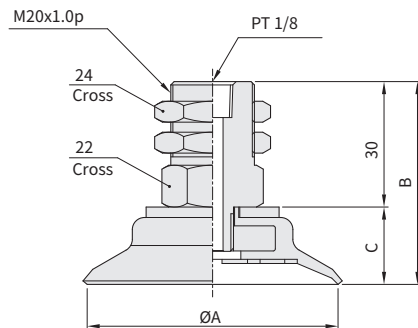

Unit: mm

Pad type	Model	Pad dia. A	Whole length B	C	Size of joint
Circle pad	PAK-60	Ø60	48.5	18.5	PT 1/8
	PAK-80	Ø80	50.5	20.5	

PA
真空吸盤
單層型

PB
真空吸盤
雙層型

PC
真空吸盤
三層型

PAG
薄型吸盤

PAO
防滑吸盤

PAP
平板型吸盤

PAQ
無痕型吸盤

PAW
橢圓型吸盤

PAL
不迴轉
真空吸盤

PBL
不迴轉
真空吸盤

PCL
不迴轉
真空吸盤

PAR
擺動
支架組

PS
非接觸式
吸盤

VP
真空
防脫落閥

PA□ series 1-Stage Vacuum Pad

Dimensions-PAT series/ Side entry

CHELIC

Ø2 ~ Ø3.5

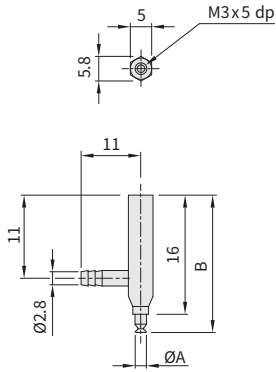

Unit: mm

Pad type	Model	Pad dia. A	Whole length B	Size of PU tube
Circle pad	PAT-02	Ø2	20	PU tube Ø4 x Ø2.5
	PAT-3.5	Ø3.5	20	

Ø5 ~ Ø8

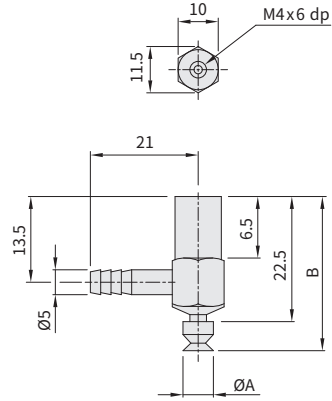

Unit: mm

Pad type	Model	Pad dia. A	Whole length B	Size of PU tube
Circle pad	PAT-05	Ø5	29	PU tube Ø6 x Ø4
	PAT-06	Ø6	29	
	PAT-08	Ø8	29.5	

Ø10 ~ Ø15

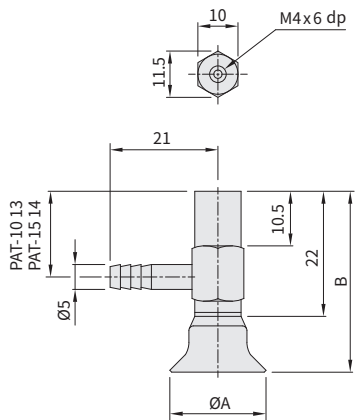

Unit: mm

Pad type	Model	Pad dia. A	Whole length B	Size of PU tube
Circle pad	PAT-10	Ø10	30	PU tube Ø6 x Ø4
	PAT-15	Ø15	30	

Ø20 ~ Ø50

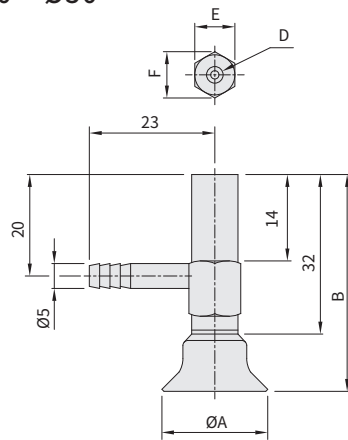

Unit: mm

Pad type	Model	Pad dia. A	Whole length B	D	E	F	Size of PU tube
Circle pad	PAT-20	Ø20	42	M6 x 1 dp8	14	16.5	PU tube Ø6 x Ø4
	PAT-25	Ø25	46				
	PAT-30	Ø30	44				
	PAT-35	Ø35	46				
	PAT-40	Ø40	46				
	PAT-50	Ø50	47				

PA□ series 1-Stage Vacuum Pad

Dimensions-PAT series/ Side entry

CHELIC

■ Ø60, Ø80

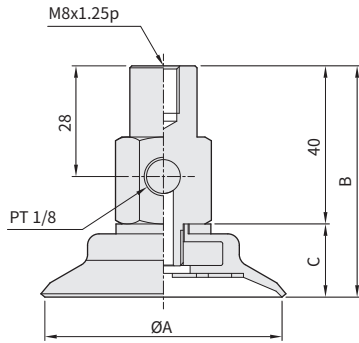

■ Ø100

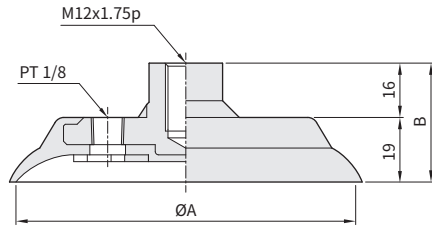

Unit: mm

Pad type	Model	Pad dia. A	Whole length B	C	Size of joint
Circle pad	PAT-60	Ø60	58.5	18.5	PT 1/8
	PAT-80	Ø80	60.5	20.5	

Unit: mm

Pad type	Model	Pad dia. A	Whole length B	Size of joint
Circle pad	PAT-100	Ø100	35	PT 1/8

■ Ø120, Ø150, Ø200

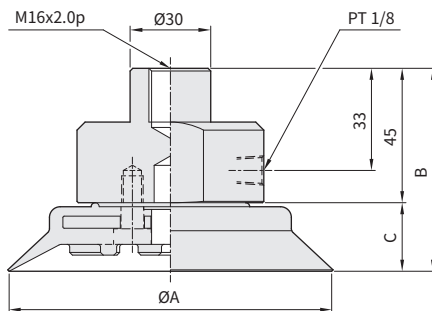

Unit: mm

Pad type	Model	Pad dia. A	Whole length B	C	Size of joint
Circle pad	PAT-120	Ø120	70.5	25.5	PT 1/8
	PAT-150	Ø150	77.5	32.5	
	PAT-200	Ø200	82.5	37.5	

PA
真空吸盤
單層型

PB
真空吸盤
雙層型

PC
真空吸盤
三層型

PAG
薄型吸盤

PAO
防滑吸盤

PAP
平板型吸盤

PAQ
無痕型吸盤

PAW
橢圓型吸盤

PAL
不迴轉
真空吸盤

PBL
不迴轉
真空吸盤

PCL
不迴轉
真空吸盤

PAR
擺動
支架組

PS
非接觸式
吸盤

VP
真空
防脫落閥

PA□ series 1-Stage Vacuum Pad

Dimensions-PAFS series/ Vertical entry with spring

CHELIC

Ø2 ~ Ø3.5

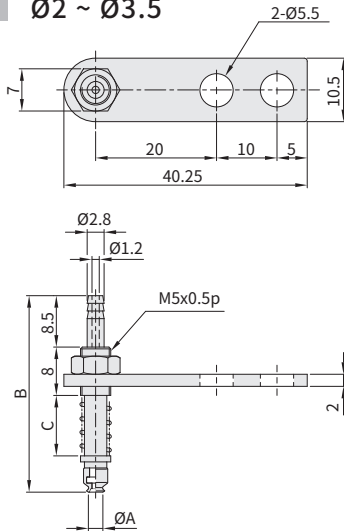

Ø5 ~ Ø8

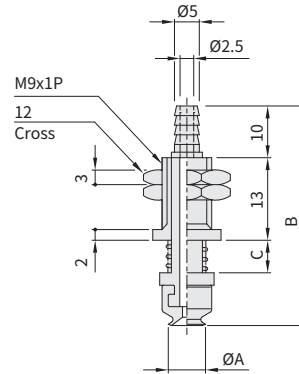

Unit: mm

Pad type	Model	Pad dia. A	Stroke 2.5		Stroke 5		Size of PU tube	Spring compression length
			B	C	B	C		
Circle pad	PAFS-02	Ø2	28.5	5.1	33.5	10.1	PU tube Ø4xØ2.5	2.5, 5
	PAFS-3.5	Ø3.5	28.5	5.1	33.5	10.1		

Unit: mm

Pad type	Model	Pad dia. A	Stroke 3		Stroke 10		Size of PU tube	Spring compression length
			B	C	B	C		
Circle pad	PAFS-05	Ø5	37.5	6	51.5	20	PU tube Ø6 x Ø4	3, 10
	PAFS-06	Ø6	37.5	6	51.5	20		
	PAFS-08	Ø8	38	6	52	20		

Ø10 ~ Ø15

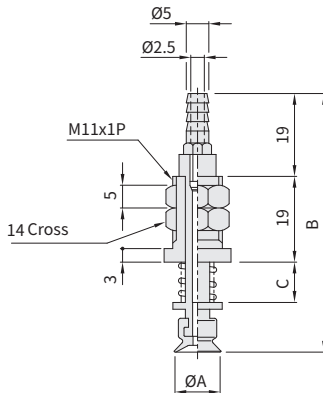

Ø20 ~ Ø50

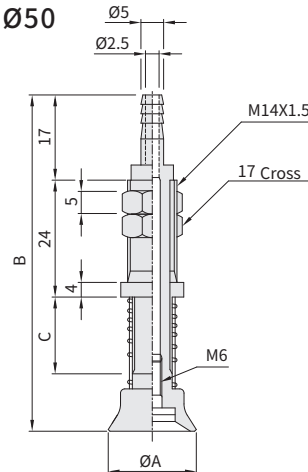

Unit: mm

Pad type	Model	Pad dia. A	Stroke 4		Stroke 10		Size of PU tube	Spring compression length
			B	C	B	C		
Circle pad	PAFS-10	Ø10	59.5	8	71.5	20	PU tube Ø6xØ4	4, 10
	PAFS-15	Ø15	57	8	69	20		

Unit: mm

Pad type	Model	Pad dia. A	Stroke 6		Stroke 15		Size of PU tube	Spring compression length
			B	C	B	C		
Circle pad	PAFS-20	Ø20	69.5	13	86.5	30	PU tube Ø6 x Ø4	6, 15
	PAFS-25	Ø25	73.5	13	90.5	30		
	PAFS-30	Ø30	71.5	13	88.5	30		
	PAFS-35	Ø35	73.5	13	90.5	30		
	PAFS-40	Ø40	71	13	88	30		
	PAFS-50	Ø50	72	13	89	30		

PA□ series 1-Stage Vacuum Pad

Dimensions-PATS series/ Side entry with spring

CHELIC

■ Ø2 ~ Ø3.5

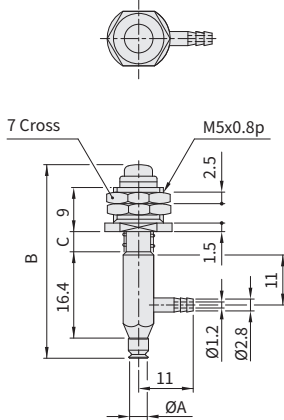

■ Ø5 ~ Ø8

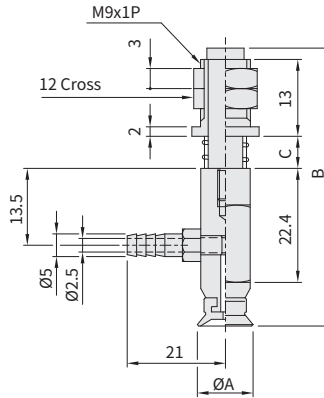

Unit: mm

Pad type	Model	Pad dia. A	Stroke 2.5		Stroke 5		Size of PU tube	Spring compression length
			B	C	B	C		
Circle pad	PATS-02	Ø2	35.7	4.5	40.5	9.5	PU tube Ø4xØ2.5	2.5, 5
	PATS-3.5	Ø3.5	35.7	4.5	40.7	9.5		
Oblong pad	PATS-2x4	2x4	37.4	4.5	42.4	9.5		
	PATS-3.5x7	3.5x7	38.2	4.5	43.2	9.5		

Unit: mm

Pad type	Model	Pad dia. A	Stroke 3		Stroke 10		Size of PU tube	Spring compression length
			B	C	B	C		
Circle pad	PATS-05	Ø5	51	6	65	20	PU tube Ø6 x Ø4	3, 10
	PATS-06	Ø6	51	6	65	20		
	PATS-08	Ø8	51.5	6	65.5	20		

■ Ø10 ~ Ø15

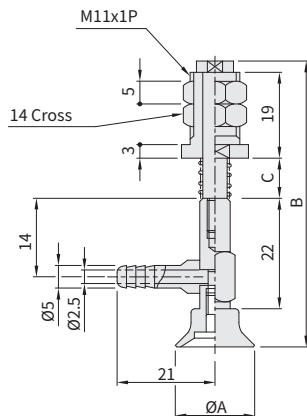

■ Ø20 ~ Ø50

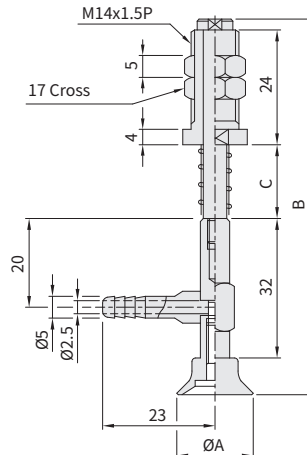

Unit: mm

Pad type	Model	Pad dia. A	Stroke 4		Stroke 10		Size of PU tube	Spring compression length
			B	C	B	C		
Circle pad	PATS-10	Ø10	60	8	72	20	PU tube Ø6xØ4	4, 10
	PATS-15	Ø15	60	8	72	20		

Unit: mm

Pad type	Model	Pad dia. A	Stroke 6		Stroke 15		Size of PU tube	Spring compression length
			B	C	B	C		
Circle pad	PATS-20	Ø20	83	13	96	30	PU tube Ø6 x Ø4	6, 15
	PATS-25	Ø25	87	13	104	30		
	PATS-30	Ø30	85	13	102	30		
	PATS-35	Ø35	87	13	104	30		
	PATS-40	Ø40	87	13	104	30		
	PATS-50	Ø50	88	13	105	30		

PA
真空吸盤
單層型

PB
真空吸盤
雙層型

PC
真空吸盤
三層型

PAG
薄型吸盤

PAO
防滑吸盤

PAP
平板型吸盤

PAQ
無痕型吸盤

PAW
橢圓型吸盤

PAL
不迴轉
真空吸盤

PBL
不迴轉
真空吸盤

PCL
不迴轉
真空吸盤

PAR
擺動
支架組

PS
非接觸式
吸盤

VP
真空
防脫落閥

PA□ series 1-Stage Vacuum Pad

Dimensions-PATS series/ Side entry with spring

CHELIC

■ Ø60, Ø80

■ Ø100

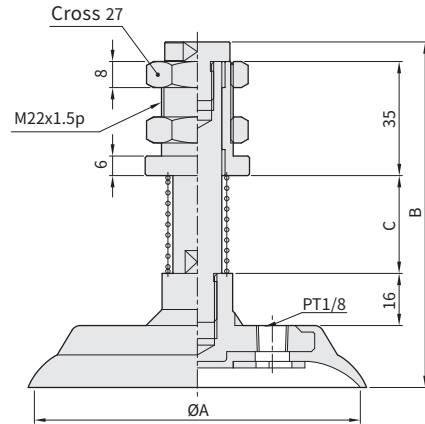
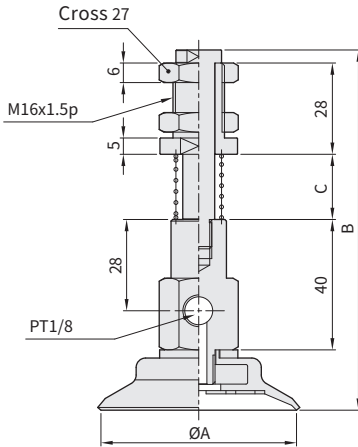

Unit: mm

Pad type	Model	Pad dia. A	Stroke 10		Stroke 30		Size of PU tube	Spring compression length
			B	C	B	C		
Circle pad	PATS-60	Ø60	110.5	20	150.5	60	PT 1/8	10, 30
	PATS-80	Ø80	112.5	20	150.5	60		

Unit: mm

Pad type	Model	Pad dia. A	Stroke 15		Stroke 30		Size of PU tube	Spring compression length
			B	C	B	C		
Circle pad	PATS-100	Ø100	106	30	136	60	PT 1/8	15, 30

■ Ø120, 150, Ø200

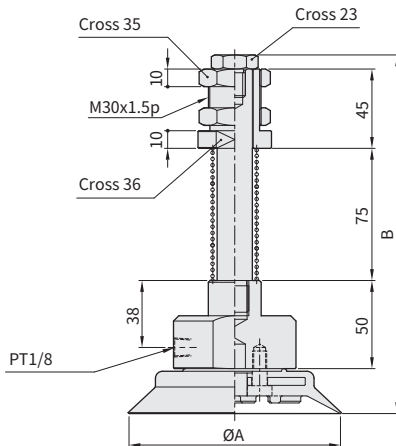

Unit: mm

Pad type	Model	Pad dia. A	Whole length B	Size of joint	Spring compression length
Circle pad	PATS-120	Ø120	203.5	PT 1/8	30
	PATS-150	Ø150	210.5		
	PATS-200	Ø200	215.5		

PA□ series 1-Stage Vacuum Pad

Dimensions-PAF-R series/ Vertical entry-Ball joint type

CHELIC

■ Ø5, Ø6, Ø8

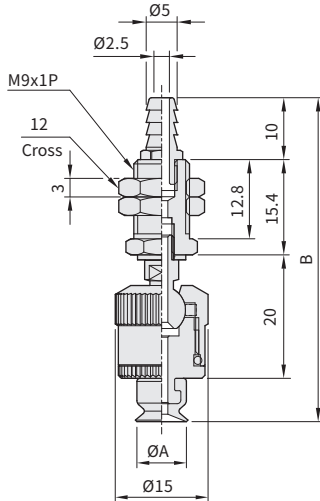

Unit: mm

Pad type	Model	Pad dia. A	Whole length B	Size of PU tube
Circle pad	PAF-05-R	Ø5	51.9	PU tube 6 x 4
	PAF-06-R	Ø6	51.9	
	PAF-08-R	Ø8	52.4	

■ Ø10, Ø15

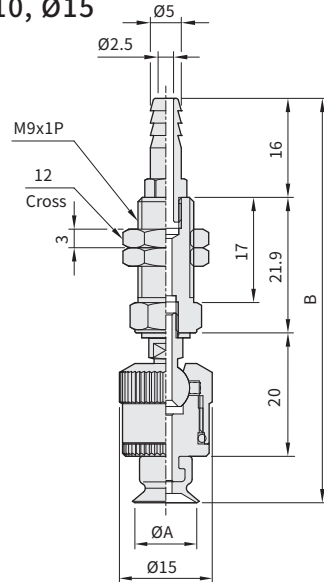

Unit: mm

Pad type	Model	Pad dia. A	Whole length B	Size of PU tube
Circle pad	PAF-10-R	Ø10	65.4	PU tube 6 x 4
	PAF-15-R	Ø15	65.9	

■ Ø20 ~ Ø50

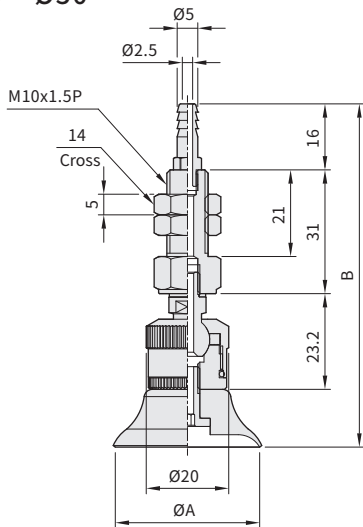

Unit: mm

Pad type	Model	Pad dia. A	Whole length B	Size of PU tube
Circle pad	PAF-20-R	Ø20	79.2	PU tube 6 x 4
	PAF-25-R	Ø25	83.2	
	PAF-30-R	Ø30	81.2	
	PAF-35-R	Ø35	83.2	
	PAF-40-R	Ø40	83.2	
	PAF-50-R	Ø50	84.2	

■ Ø60 ~ Ø80

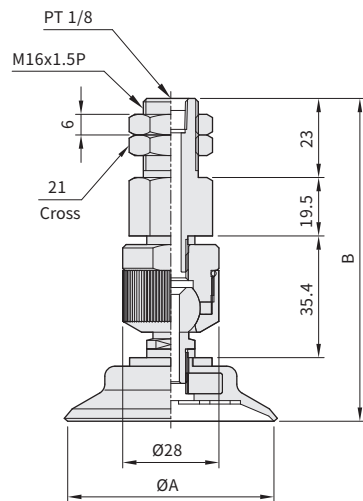

Unit: mm

Pad type	Model	Pad dia. A	Whole length B	Size of PU tube
Circle pad	PAF-60-R	Ø60	94	PT 1/8
	PAF-80-R	Ø80	96	

PA
真空吸盤
單層型

PB
真空吸盤
雙層型

PC
真空吸盤
三層型

PAG
薄型吸盤

PAO
防滑吸盤

PAP

平板型吸盤

PAQ
無痕型吸盤

PAW
橢圓型吸盤

PAL
不迴轉
真空吸盤

PBL
不迴轉
真空吸盤

PCL
不迴轉
真空吸盤

PAR
擺動
支架組

PS
非接觸式
吸盤

VP
真空
防脫落閥

PA□ series 1-Stage Vacuum Pad

Dimensions-PAK-R series/ Vertical entry with fitting-Ball joint type

CHELIC

■ Ø10, Ø15

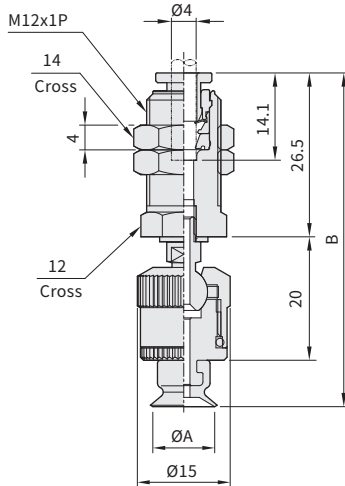

Unit: mm

Pad type	Model	Pad dia. A	Whole length B	Size of PU tube
Circle pad	PAK-10-R	Ø10	54	PU tube Ø4 x Ø2.5
	PAK-15-R	Ø15	54.5	

■ Ø20 ~ Ø50

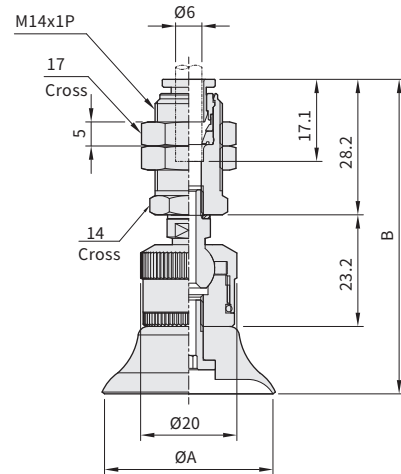

Unit: mm

Pad type	Model	Pad dia. A	Whole length B	Size of PU tube
Circle pad	PAK-20-R	Ø20	61.4	PU tube 6 x 4
	PAK-25-R	Ø25	65.4	
	PAK-30-R	Ø30	64.4	
	PAK-35-R	Ø35	65.4	
	PAK-40-R	Ø40	65.4	
	PAK-50-R	Ø50	66.4	

■ Ø60, Ø80

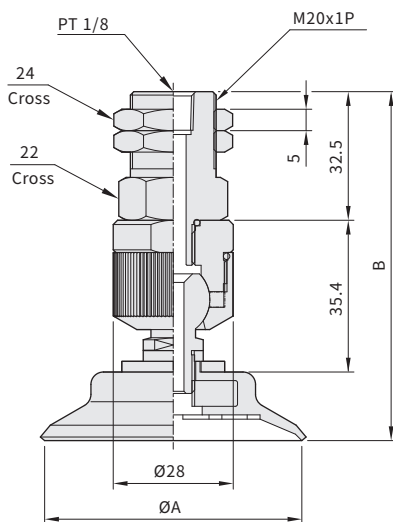

Unit: mm

Pad type	Model	Pad dia. A	Whole length B	Size of PU tube
Circle pad	PAK-60-R	Ø60	81.5	PT 1/8
	PAK-80-R	Ø80	83.5	

PA□ series 1-Stage Vacuum Pad

Dimensions-PAT-R series/ Side entry-Ball joint type

CHELIC

■ Ø5 ~ Ø15

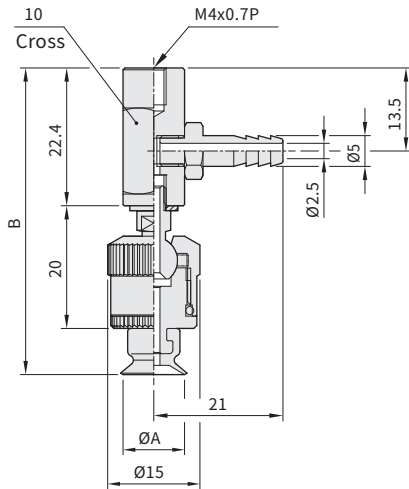

Unit: mm

Pad type	Model	Pad dia. A	Whole length B	Size of PU tube
Circle pad	PAT-05-R	Ø5	51.9	PU tube 6 x 4
	PAT-06-R	Ø6	52.4	
	PAT-08-R	Ø8	52.4	
	PAT-10-R	Ø10	55.9	
	PAT-15-R	Ø15	62.9	

■ Ø20 ~ Ø50

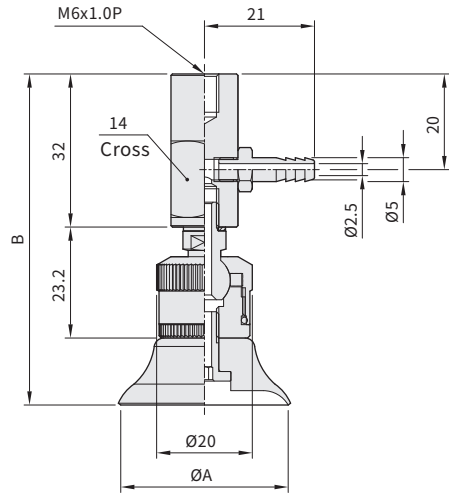

Unit: mm

Pad type	Model	Pad dia. A	Whole length B	Size of PU tube
Circle pad	PAT-20-R	Ø20	65.2	PU tube 6 x 4
	PAT-25-R	Ø25	69.2	
	PAT-30-R	Ø30	67.2	
	PAT-35-R	Ø35	69.2	
	PAT-40-R	Ø40	69.2	
	PAT-50-R	Ø50	70.2	

■ Ø60, Ø80

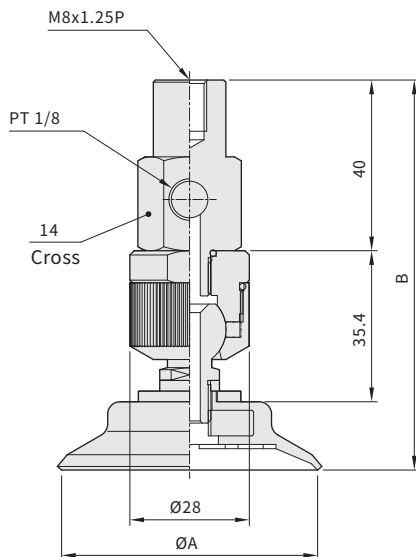

Unit: mm

Pad type	Model	Pad dia. A	Whole length B	Size of PU tube
Circle pad	PAT-60-R	Ø60	91.5	PT 1/8
	PAT-80-R	Ø80	93.5	

PA
真空吸盤
單層型

PB
真空吸盤
雙層型

PC
真空吸盤
三層型

PAG
薄型吸盤

PAO
防滑吸盤

PAP
平板型吸盤

PAQ
無痕型吸盤

PAW
橢圓型吸盤

PAL
不迴轉
真空吸盤

PBL
不迴轉
真空吸盤

PCL
不迴轉
真空吸盤

PAR
擺動
支架組

PS
非接觸式
吸盤

VP
真空
防脫落閥

PA□ series 1-Stage Vacuum Pad

Dimensions-PAFS-R series/ Vertical entry with spring-Ball joint type

CHELIC

■ Ø5, Ø6, Ø8

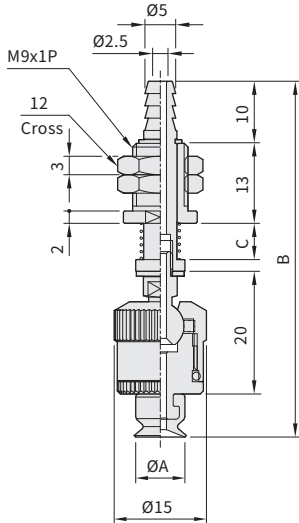

Unit: mm

Pad type	Model	Pad dia. A	Stroke 3			Stroke 10			Size of PU tube	Spring compression length
			B	C	B	C	C			
Circle pad	PAFS-05-R	Ø5	57.4	6	71.4	20		PU tube 6 x 4	3, 10	
	PAFS-06-R	Ø6	57.4	6	71.4	20				
	PAFS-08-R	Ø8	57.9	6	71.9	20				

■ Ø10, Ø15

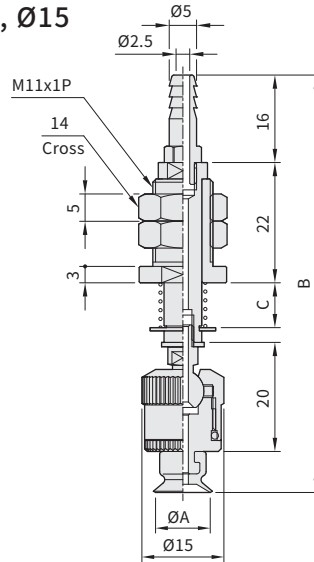

Unit: mm

Pad type	Model	Pad dia. A	Stroke 4			Stroke 10			Size of PU tube	Spring compression length
			B	C	B	C	C			
Circle pad	PAFS-10-R	Ø10	76.4	8	88.4	20		PU tube 6 x 4	4, 10	
	PAFS-15-R	Ø15	76.9	8	88.9	20				

■ Ø20 ~ Ø50

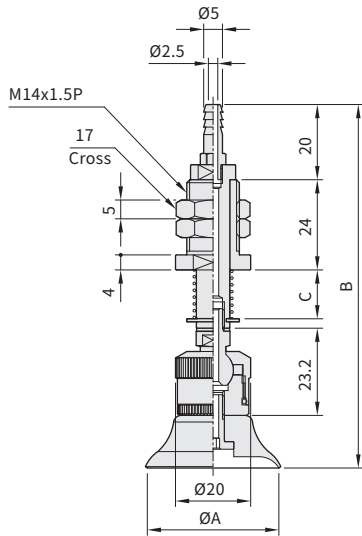

Unit: mm

Pad type	Model	Pad dia. A	Stroke 6			Stroke 15			Size of PU tube	Spring compression length
			B	C	B	C	C			
Circle pad	PAFS-20-R	Ø20	92.7	13	109.7	30		PU tube 6 x 4	6, 15	
	PAFS-25-R	Ø25	96.7	13	113.7	30				
	PAFS-30-R	Ø30	94.7	13	111.7	30				
	PAFS-35-R	Ø35	96.7	13	113.7	30				
	PAFS-40-R	Ø40	96.7	13	113.7	30				
	PAFS-50-R	Ø50	97.7	13	114.7	30				

PA□ series 1-Stage Vacuum Pad

Dimensions-PATS-R series/ Side entry with spring-Ball joint type

CHELIC

Ø5, Ø6, Ø8

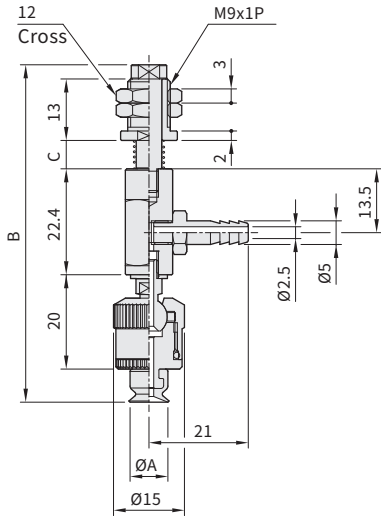

Unit: mm

Pad type	Model	Pad dia. A	Stroke 3			Size of PU tube	Spring compression length
			B	C	C		
Circle pad	PATS-05-R	Ø5	70.9	6	84.9	PU tube 6 x 4	3, 10
	PATS-06-R	Ø6	70.9	6	84.9		
	PATS-08-R	Ø8	71.4	6	85.4		

Ø10, Ø15

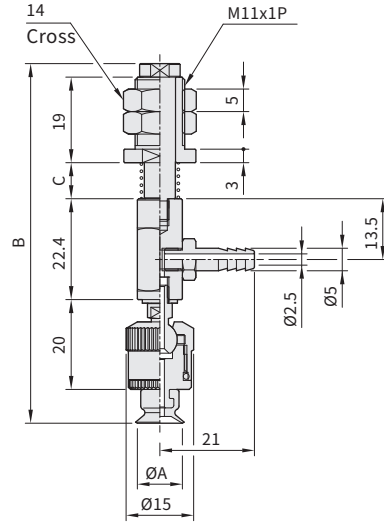

Unit: mm

Pad type	Model	Pad dia. A	Stroke 4			Stroke 10	Size of PU tube	Spring compression length
			B	C	B			
Circle pad	PATS-10-R	Ø10	80	8	92	20	PU tube 6 x 4	4, 10
	PATS-15-R	Ø15	80.5	8	92.5	20		

Ø20 ~ Ø50

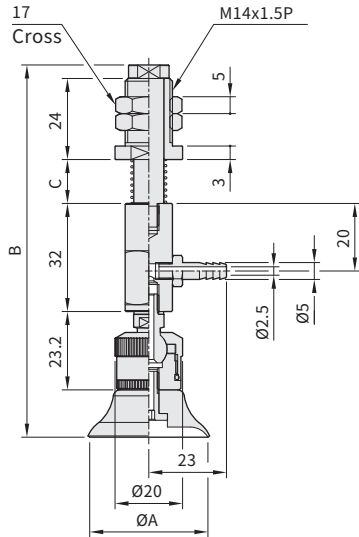

Unit: mm

Pad type	Model	Pad dia. A	Stroke 6			Stroke 15			Size of PU tube	Spring compression length
			B	C	C	B	C	C		
Circle pad	PATS-20-R	Ø20	106.2	13	123.2	30	PU tube 6 x 4	6, 15		
	PATS-25-R	Ø25	110.2	13	127.2	30				
	PATS-30-R	Ø30	108.2	13	125.2	30				
	PATS-35-R	Ø35	110.2	13	127.2	30				
	PATS-40-R	Ø40	110.2	13	127.2	30				
	PATS-50-R	Ø50	111.2	13	127.2	30				

Ø60, Ø80

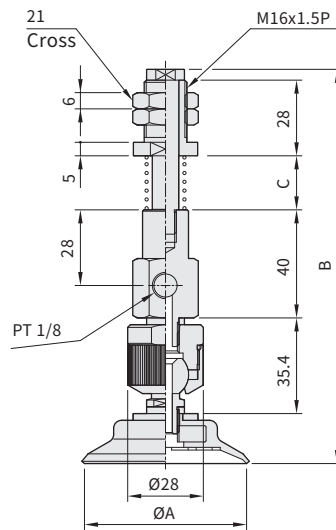

Unit: mm

Pad type	Model	Pad dia. A	Stroke 10			Stroke 30			Size of PU tube	Spring compression length
			B	C	C	B	C	C		
Circle pad	PATS-60-R	Ø60	146	20	186	60	PT 1/8	10, 30		
	PATS-80-R	Ø80	148	20	188	60				

PA
真空吸盤
單層型

PB
真空吸盤
雙層型

PC
真空吸盤
三層型

PAG
薄型吸盤

PAO
防滑吸盤

PAP
平板型吸盤

PAQ
無痕型吸盤

PAW
橢圓型吸盤

PAL
不迴轉
真空吸盤

PBL
不迴轉
真空吸盤

PCL
不迴轉
真空吸盤

PAR
擺動
支架組

PS
非接觸式
吸盤

VP
真空
防脫落閥