

Actuator Unit – MSR(L)2 series

Slide table

CHELIC

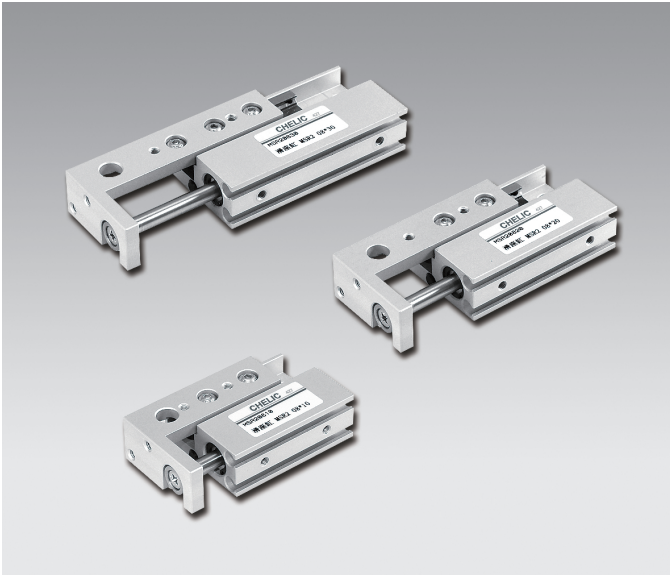

MSR(L)2 series
Provide CAD external dimension.

Feature :

1. It adopts a precise slide rail guide, low abrasion, fast and accurate driving.
2. It is available for right and left sliding types.

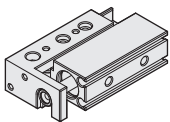

MSR2 series -- Air slide table ----- $\varnothing 6 \sim \varnothing 16$ ----- P.6-9.2

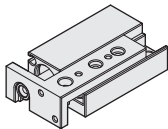

MSL2 series -- Air slide table ----- $\varnothing 6 \sim \varnothing 16$ ----- P.6-9.2

MSR(L)2 series Air Slide Table

Product features/ Code of order

CHELIC

Internal structure

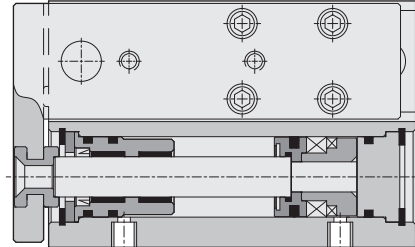
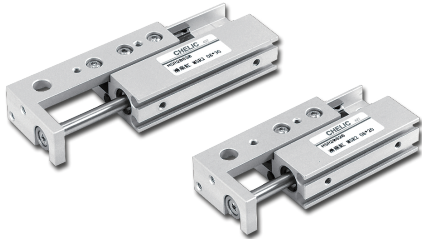

Specification

Unit: mm

Item	Bore size	Ø6	Ø8	Ø10	Ø12	Ø16
Action		Double acting				
Fluid		Air				
Pressure range	Kgf/cm ² (kPa)	2~7(200~700)		1.5~7(150~700)		
Ambient and fluid temperature	°C	0 ~ 60				
Piston speed	mm/s	50 ~ 200				
Port size		M3x0.5P			M5x0.8P	
Lubrication		Lubrication free type				
Sensing device		With magnet				

Code of order

MSR2 × 06 × 10 - SD 2

Model Bore size Stroke Sensor switch

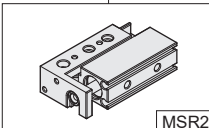

MSR2

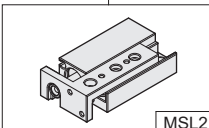

MSL2

06 - Ø6 mm
08 - Ø8 mm
10 - Ø10 mm
12 - Ø12 mm
16 - Ø16 mm

10 : 10 mm
20 : 20 mm
30 : 30 mm

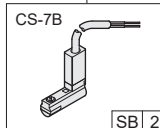

CS-7B

SB 2

None: Without sensor switch
 [SB]: Sensor switch mark (CS-7B)
 (Applicable to Ø6 bore size)

[2]: Quantity of sensor switch
 2 = 2 PCS

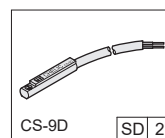

None: Without sensor switch
 [SD]: Sensor switch mark (CS-9D)
 [SB]: Sensor switch mark (CS-9B)
 (Applicable to Ø6 bore size)

[2]: Quantity of sensor switch
 2 = 2 PCS

MSR(L)2

FMR(L)

MQX

MTX

MDQ2

MDQA

MDX

MDXL

MBX

MGX

MSR(L)2 series Air Slide Table

Product features

CHELIC

Internal structure

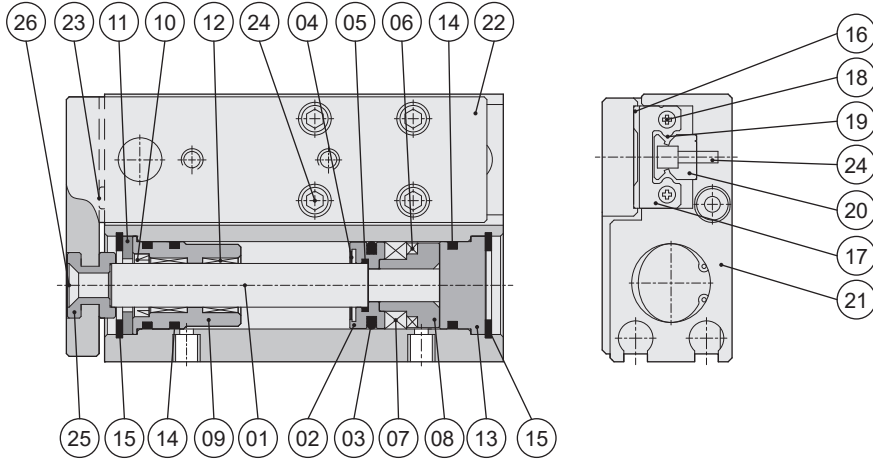

Components and material list

No.	Item	Material	No.	Item	Material
01	Shaft	Carbon steel	14	O-ring	NBR
02	Piston	Copper Alloy	15	C clip	Spring steel
03	Piston Packing	NBR	16	Slide base	Bearing steel
04	Cushion gasket	NBR	17	Block	Stainless steel
05	O-ring	NBR	18	Countersunk screw	Alloy steel
06	Magnet	Rare earth	19	Roller	Bearing steel
07	Wear ring	Teflon	20	Rail	Bearing steel
08	Magnet base	Aluminum alloy	21	Body	Aluminum alloy
09	Front cover	Aluminum alloy	22	Slider	Aluminum alloy
10	Shaft packing	NBR	23	Absorbing rubber	NBR
11	Packing plate	Stainless steel	24	Hexagon screw	Alloy steel
12	Bearing	Compound material	25	Shaft end block	Carbon steel
13	Rear cover	POM	26	Countersunk screw	Carbon steel

Packing and O-ring material list

Unit: mm

Item	Piston packing	Shaft packing	Front/ Rear cap O-ring
Quantity	1	1	2
Bore size			
Ø6	COP-06	MYA-3	Ø7xØ1
Ø8	DYP-8 (2PCS)	DYR-5K	Ø7xØ1
Ø10	DYP-10 (2PCS)	EM-0609	Ø6.3xØ0.8、Ø7xØ1(1PCS of each)
Ø12	APA-12	PDU-6	Ø10.7xØ1.5
Ø16	APA-16	EM-0811	Ø13.2xØ1.5 (3PCS)

MSR(L)2 series Air Slide Table

Dimensions

CHELIC

MSR2 06 ×

 MSR(L)2 06 × ST

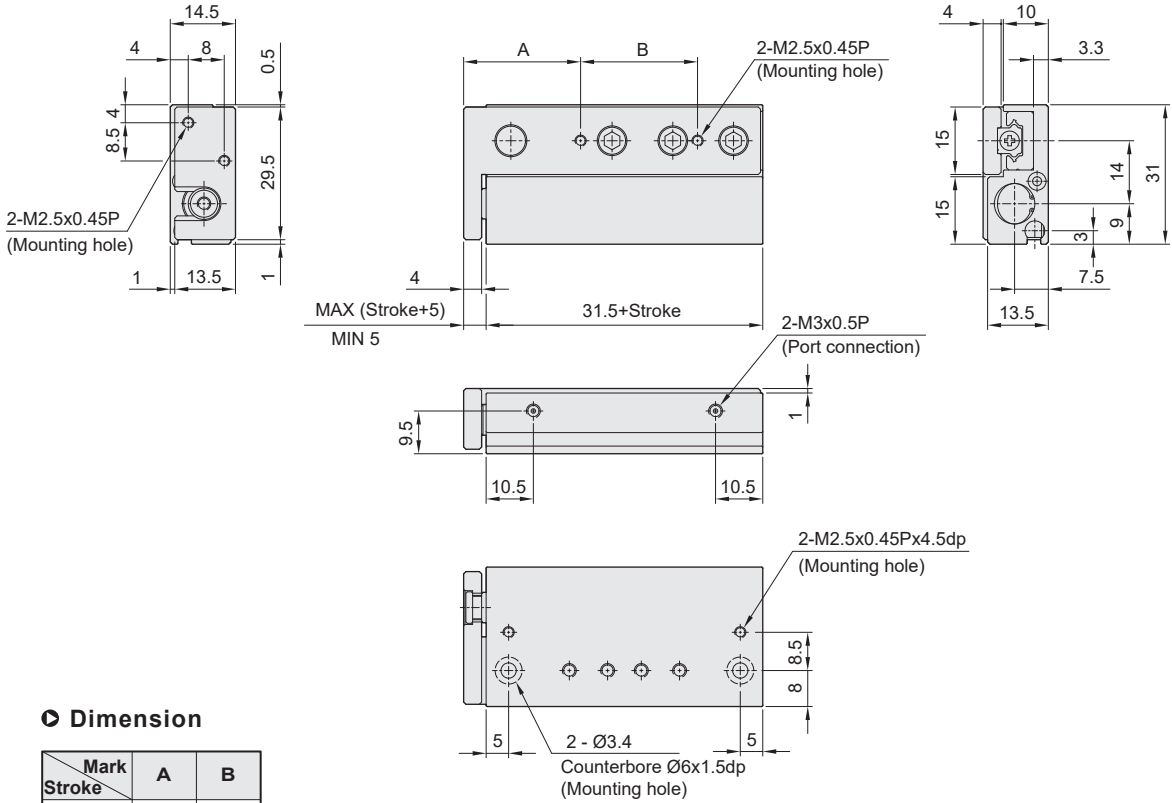

Dimension

Mark Stroke	A	B
10	15.5	15
20	19	20
30	26	26

MSL2 06 ×

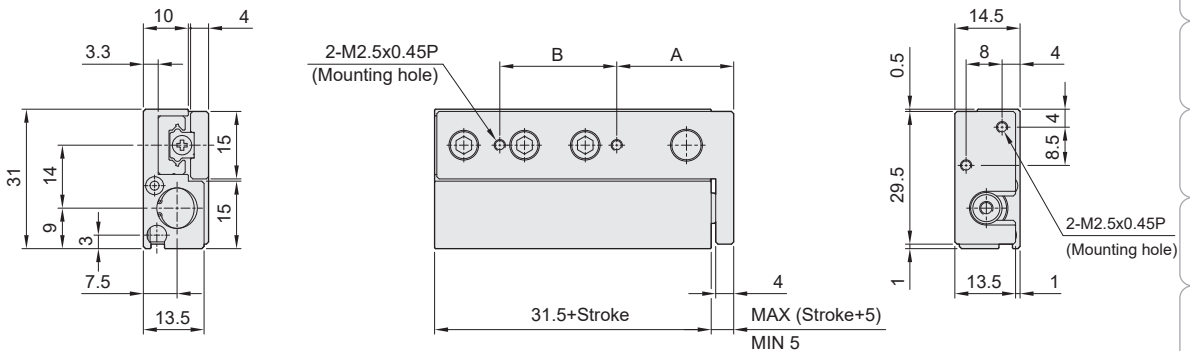

MSR(L)2

FMR(L)

MQX

MTX

MDQ2

MDQA

MDX

MDXL

MBX

MGX

MSR(L)2 series Air Slide Table

Dimensions

CHELIC

MSR2 08 ×

 MSR(L)2 08 × ST

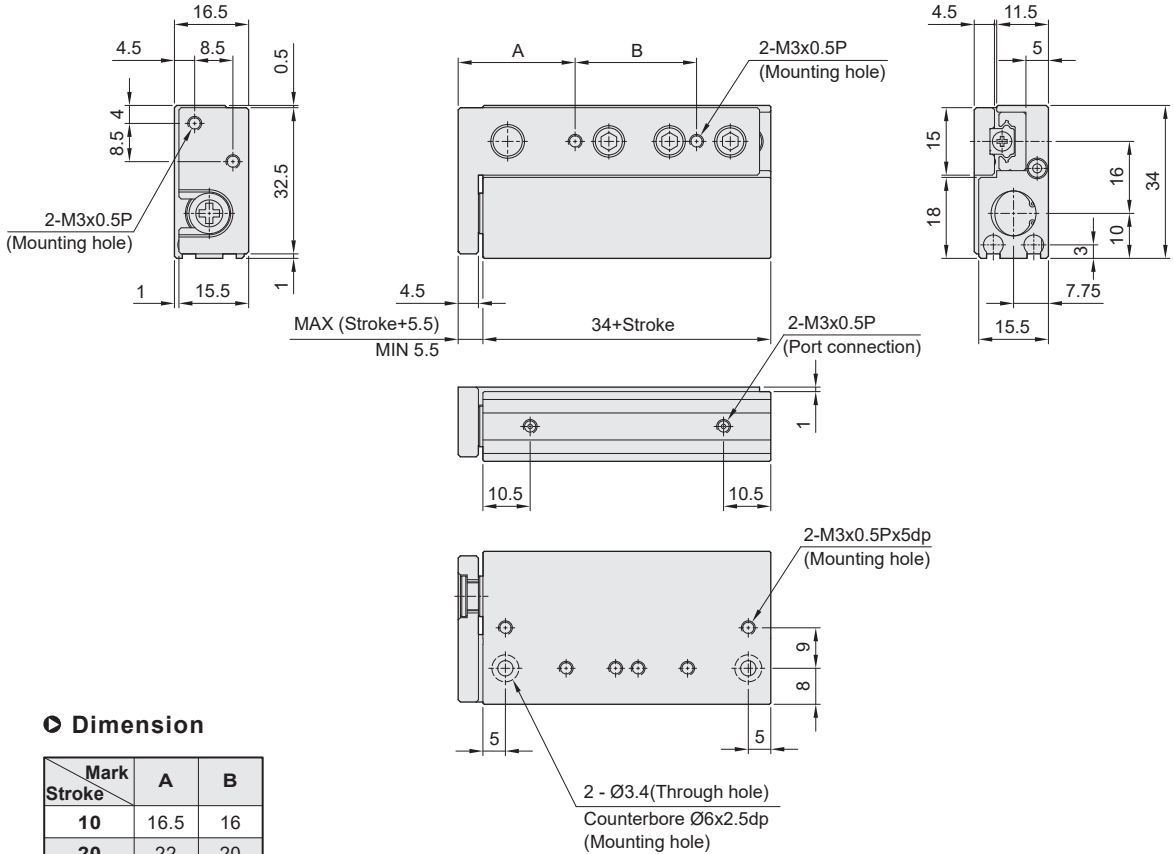

Dimension

Mark Stroke	A	B
10	16.5	16
20	22	20
30	26	27

MSL2 08 ×

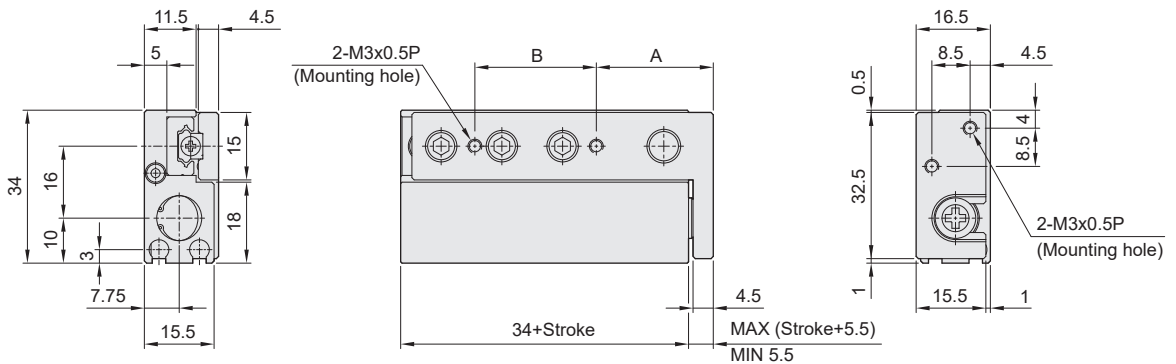

MSR(L)2 series Air Slide Table

Dimensions

CHELIC

MSR2 12 ×



MSR(L)2 12 × ST

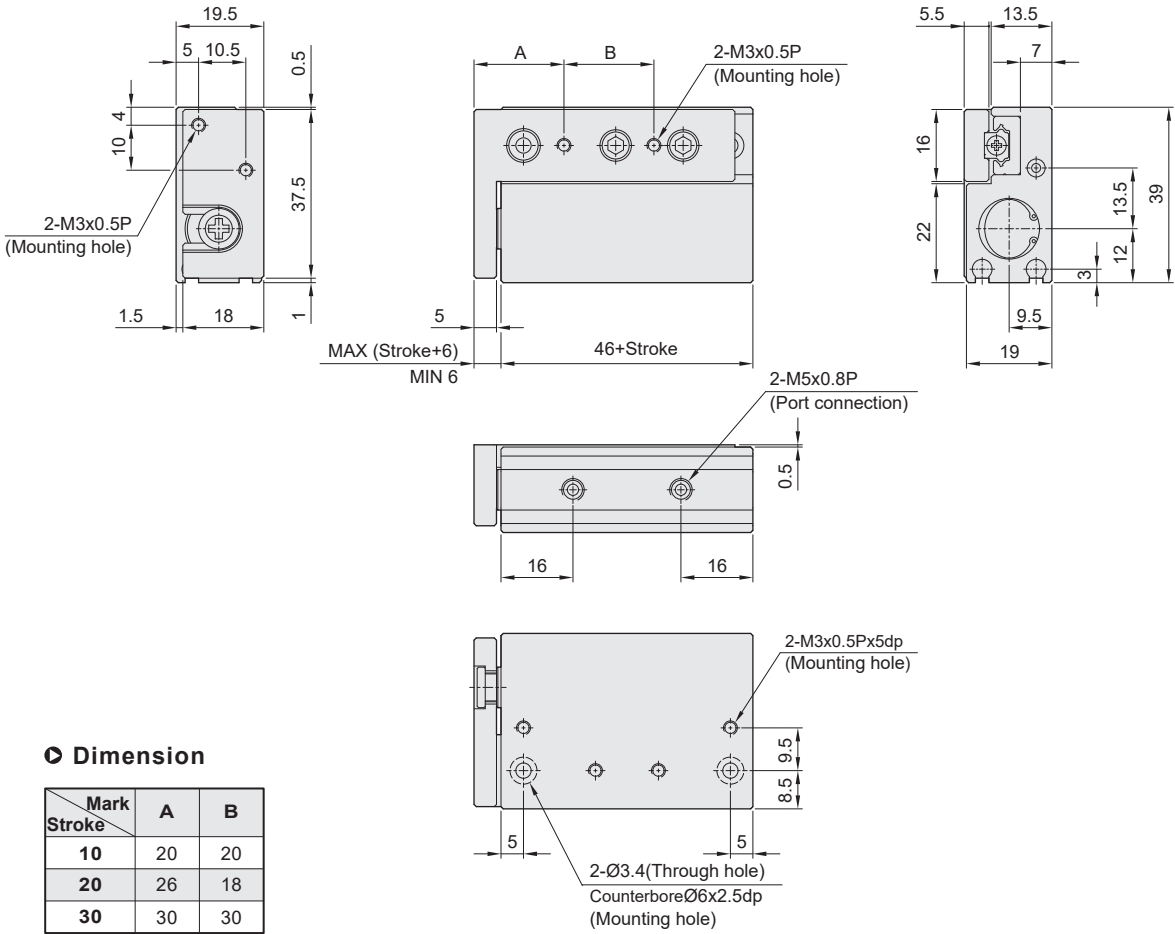

Dimension

Mark Stroke	A	B
10	20	20
20	26	18
30	30	30

MSL2 12 ×

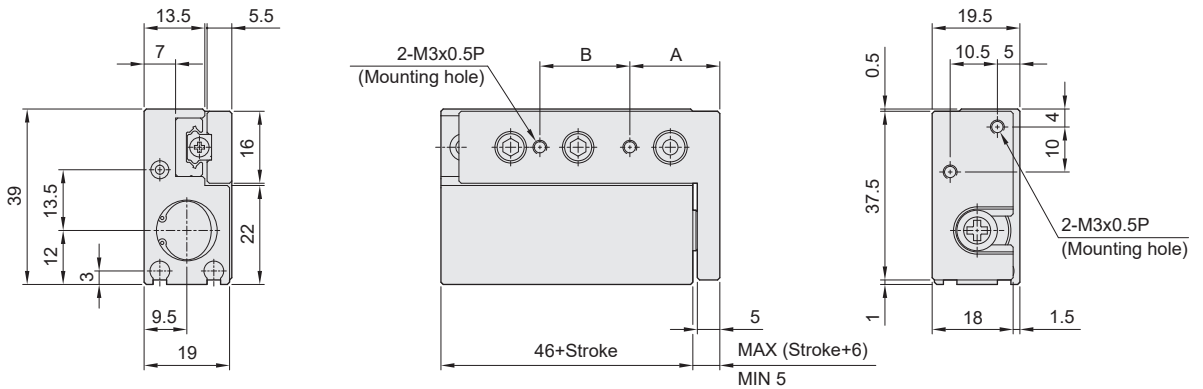

MSR(L)2 series Air Slide Table

Dimensions

CHELIC

MSR2 16 ×



MSR(L)2 16 × ST

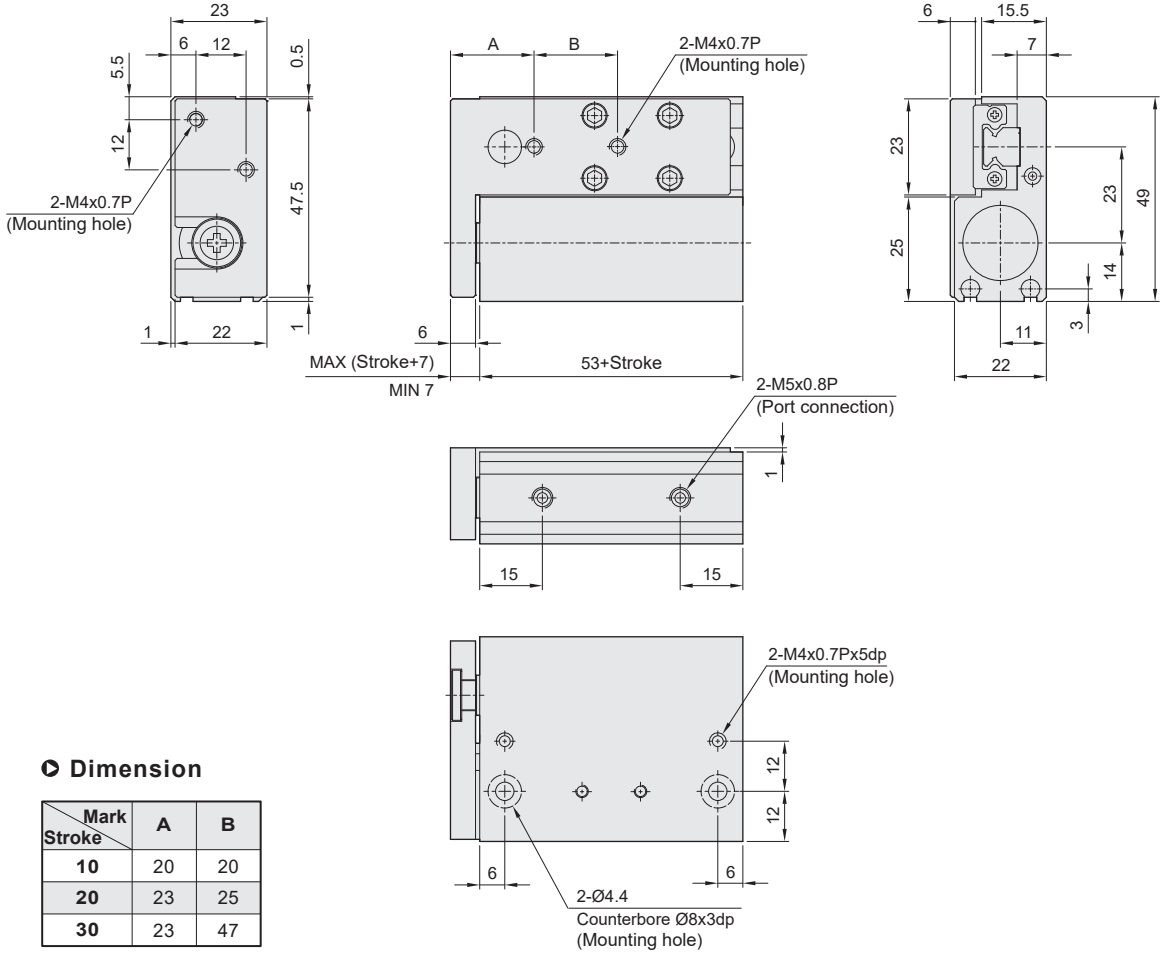

Dimension

Mark Stroke	A	B
10	20	20
20	23	25
30	23	47

MSL2 16 ×

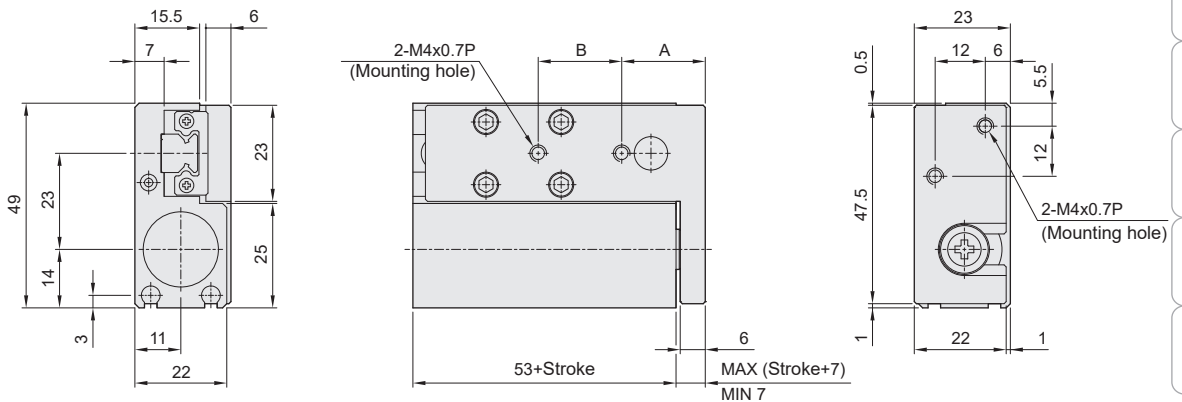

MSR(L)2

FMR(L)

MQX

MTX

MDQ2

MDQA

MDX

MDXL

MBX

MGX

MSR(L)2 series Air Slide Table

Sensor switch operating range and the setting

CHELIC

◉ Sensor switch mounting type

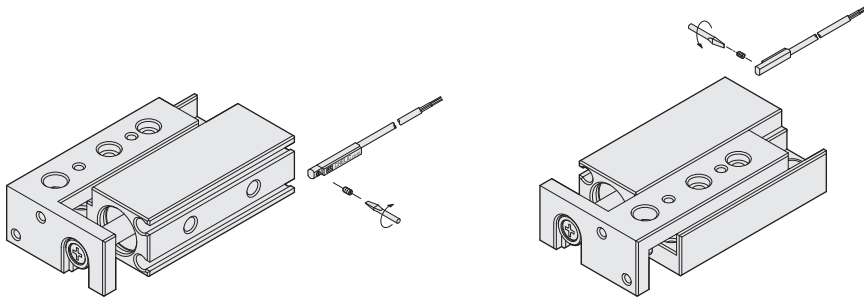

◉ Sensing range

Sensor switch is fixed on the cylinder body. The magnetic piston head will activate the Sensor switch when it enters the operating range. It has 0.5mm differential.

◉ Operating range

When piston head moves the switch setting and adjustment will be based on the responding range generated by the magnetic field and the switch. (Please refer to the below table)

Unit: mm

Model	CS-7B	
Bore size	Operating range (F)	Hysteresis(R)
Ø6	3	0.5
Ø8	-	-
Ø10	-	-
Ø12	-	-
Ø16	-	-

Unit: mm

Model	CS-9D(B)	
Bore size	Operating range (F)	Hysteresis(R)
Ø6	-	-
Ø8	6	1.0
Ø10	8	1.0
Ø12	8	1.0
Ø16	10	1.2

◉ Sensor switch setting and operating range

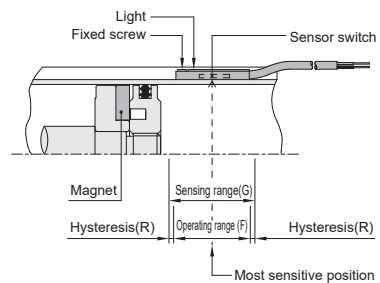

◉ Sensor switch introduction

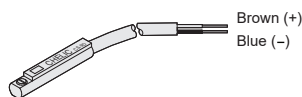

CS-9D

Voltage: DC 5~120V
AC 5~120V

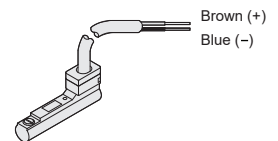

CS-9B

Voltage: DC 5~120V
AC 5~120V

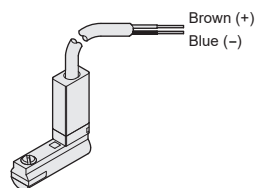

CS-7B

Voltage: DC 5 ~ 30V