

For your safety, please read the following before using.

- Do not use fluid that will corrode SUS316L, please confirm the specification before use.
- Please use within the rating pressure range. Do not apply pressure beyond recommended maximum withstand pressure, permanent damage to the pressure sensor may occur.
- Do not drop, hit or allow excessive shock. Even if switch body appears undamaged, internal components may be broken and can cause malfunction.
- Turn power off before connecting wiring. Wrong wiring or short circuit will damage and / or cause malfunction.
- This product is not explosion-proof rated. Do not use in atmosphere containing flammable or explosive gases.
- Wiring for pressure sensor should avoid power source line and high voltage line.
- If use in the same circuit, noise may cause malfunction.
- The product is complied CE certificate, but no surge absorber. If required, please find other way to solve.
- Do not exceed the maximum torque of 13.6 N.m when install piping. Over torque may cause malfunction.
- Wiring for RS485 MODBUS : Please connect RS485 (B+) or (A-) before connecting power supply to avoid short circuit to damage to product.

A. SPECIFICATIONS

MODEL	PSC-75 (Compound Pressure)	PSN-75 (Positive Pressure)	PSH-75 (High Pressure)
Rated pressure range	-100.0~100.0 kPa	0.000~1.000 MPa	0.000~2.00 MPa
Set pressure range	-101.0~101.0 kPa	-0.100~1.000 MPa	-0.100~2.00 MPa
Withstand pressure	300 kPa	3 MPa	3 MPa
Fluid	Fluid or air that will not corrode SUS316L		
Sealed liquid	Silicon oil		
Set pressure resolution	kPa	0.1	—
	MPa	—	0.001
	kgf/cm ²	0.001	0.01
	bar	0.001	0.01
	psi	0.01	0.1
	inHg	0.1	—
Power supply voltage	12 to 24V DC ±10%, Ripple (P-P) 10% or less		
Current consumption	≤ 40mA (With no load)		
Switch output	1 NPN : open collector 1 output Max. load current : 125mA Max. supply voltage : 30V DC Residual voltage : ≤ 1.5V	1 PNP : open collector 1 output Max. load current : 125mA Max. supply voltage : 24V DC Residual voltage : ≤ 1.5V	
	Repeatability	±0.3% F.S. ±1 digit	
Response time	≤ 2.5ms (chattering-proof function: 25ms, 100ms, 250ms, 500ms, 1000ms and 1500ms selections)		
Output short circuit protection	Yes		
Display	3 1/2 digital, 7 segment LCD display (Red / Green / Orange) (Sampling rate : 5 times / sec.)		
Indicator accuracy	±2% F.S. ±1 digit (Ambient temperature : 25 ±3°C)		
Switch on indicator	Orange Indicator 1 : OUT 1		
Environment	Enclosure	IP65 (*1)	
	Ambient temp. range	Operation : 0 ~ 50°C, Storage : -10 ~ 60°C (No condensation or freezing)	
	Ambient humidity range	35 ~ 85% RH (No condensation)	
	Withstand voltage	250V AC in 1-min (between case and lead wire)	
	Insulation resistance	≥ 50MΩ (at 500V DC, between case and lead wire)	
	Vibration	Total amplitude 1.5mm or 10G, 10Hz-55Hz-10Hz scan for 1 minute, 2 hours each direction of X, Y and Z	
Shock	100m/s ² (10G), 3 times each in direction of X, Y and Z		
Temperature characteristic	±3% F.S. of detected pressure (25°C) at temp. Range of 0~50°C		
Communication interface	RS485		
Port size (*2)	R : R1/4", M5, NPT : NPT1/4", #10-32UNF G : G1/4"(BSPP), M5		
Lead wire	Ø4 Oil-resistance cable (PVC) - 26AWG (0.15mm ²) - 5 cores		
Weight (With 2 meter lead wire)	Approx. 110g (Rear ported) ; Approx. 150g (Bottom ported)		

*1. Dustproof protector must be installed to maintain IP65.
*2. G port O-Ring material is NBR, if any special request, please contact us.

B. OUTPUT CIRCUIT WIRING DIAGRAMS

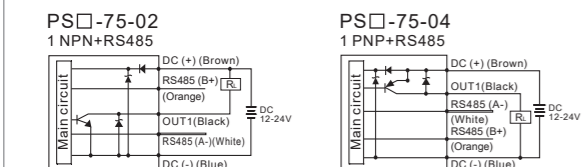

C. ORDERING INFORMATION

P S C - 7 5 - 0 2 - R

Pressure Range

C : Compound Pressure (-101.0~101.0 kPa)
N : Positive Pressure (-0.100~1.000 MPa)
H : High Pressure (-0.100~2.00 MPa)

Output Specifications

02 : 1 NPN Output + RS485
04 : 1 PNP Output + RS485

Pressure Port

R : R1/4", M5
NPT : NPT1/4", #10-32UNF
G : G1/4"(BSPP), M5

Piping Direction

Blank : Rear ported
L : Bottom ported

Optional Parts

BT-10 : Mounting bracket
BT-11 : Mounting bracket
PA-E : Panel adapter
PA-F : Panel adapter + Front protective lid
I-0360 : Snubber (for Pressure Port F1&F3)
I-0379 : Snubber (for Pressure Port F2)

*PSP-75 and PSH-75 are recommended to install a snubber to reduce shock effects. See Section "R".

D. PANEL DESCRIPTION

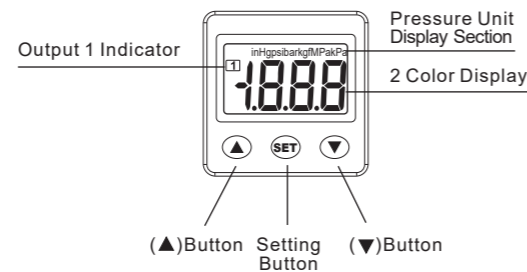

E. DIMENSIONS

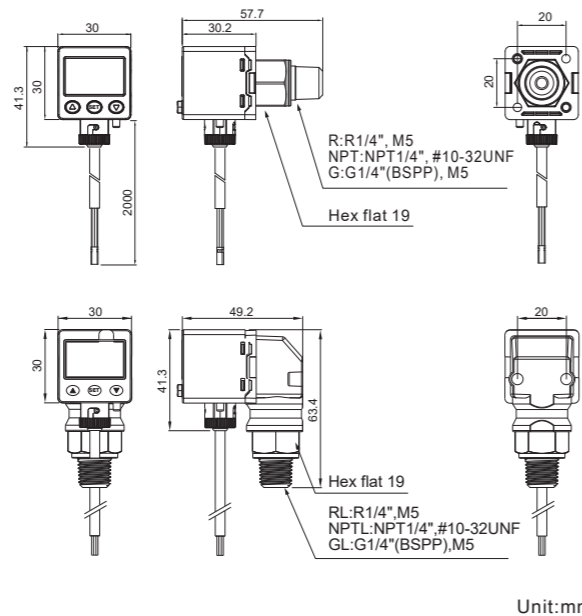

F. OPTIONAL PARTS DIMENSIONS

① Mounting Bracket

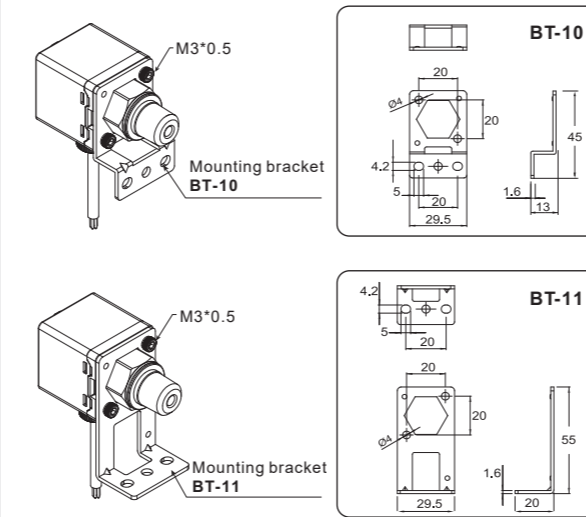

② Panel Mounting

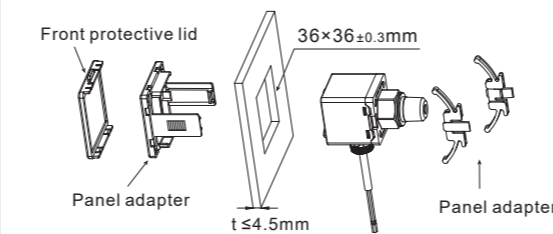

PA-E

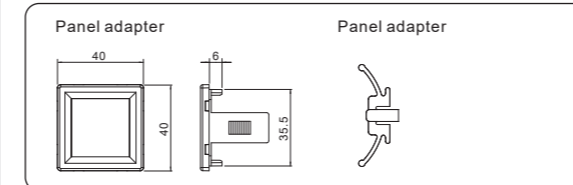

PA-F

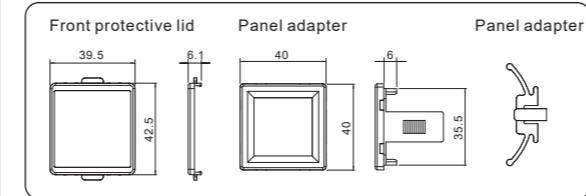

③ Accessory

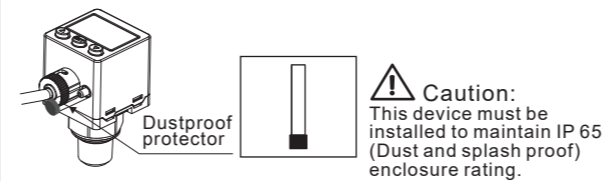

G. INITIAL SETTING MODE

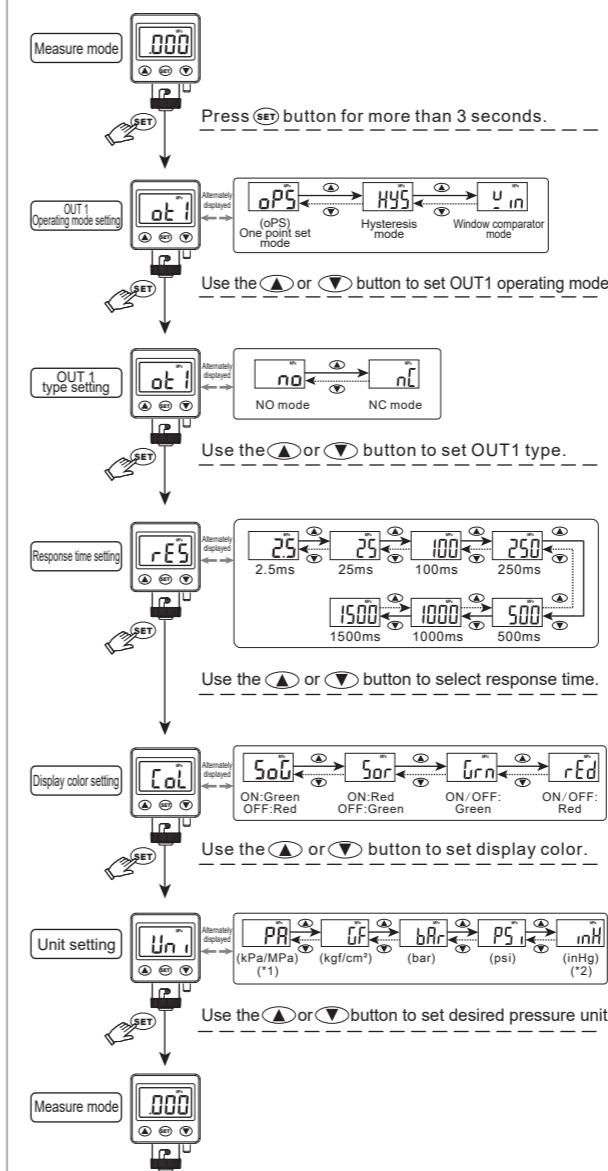

【NOTE :】
*1. Pressure unit is MPa with positive and high pressure. Pressure unit is kPa with compound pressure.
*2. Only applicable for Compound.

H. POWER-SAVE MODE

- During Power-Save mode, the main display will turned off if no buttons is pressed after 30 seconds.
- During Power-Save mode, the output LCD may not be synchronize with the output. It is normal and will not affect output operation.
- Press any button to turn-on main display temporarily.

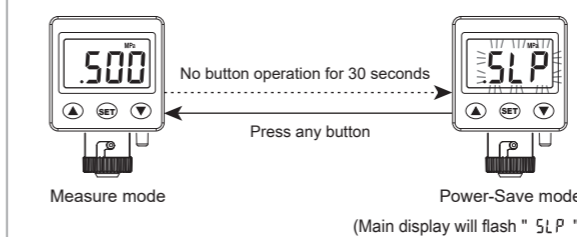

I. ADVANCE SETTING MODE

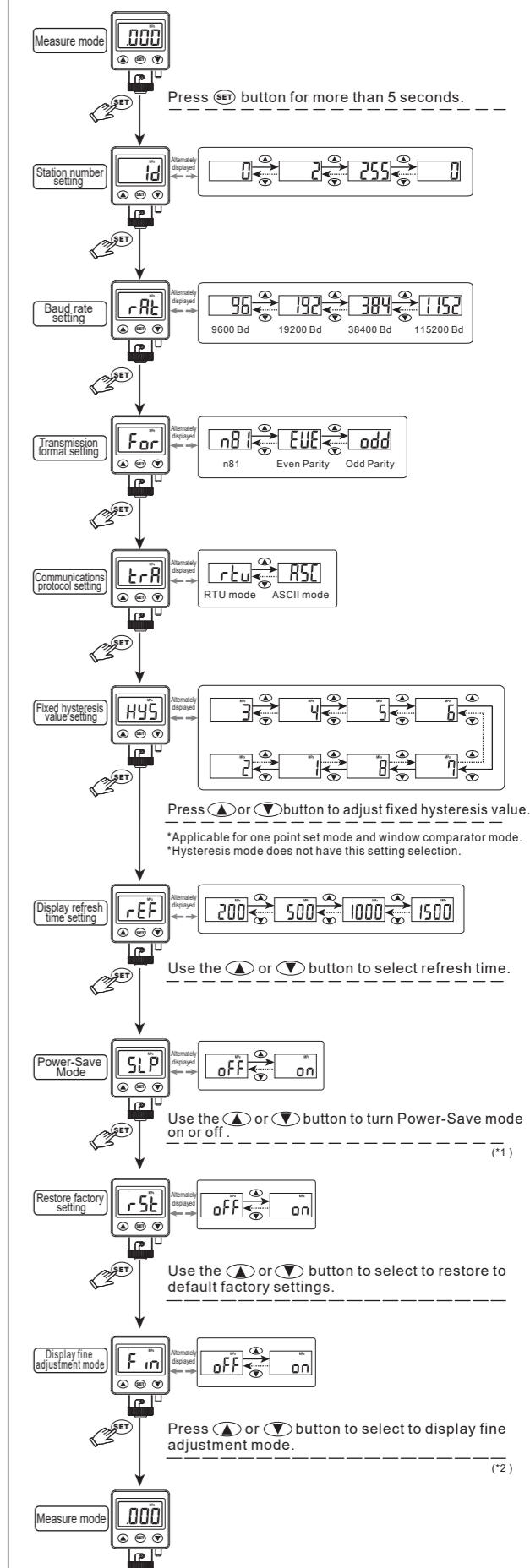

【NOTE :】
*1. When setting is "on", the power-save mode is active. Please refer to the Section "H" for details.
*2. When setting is "on", the display fine adjustment mode is active. Please refer to the Section "G" for details.

J. PRESSURE SETTING MODE

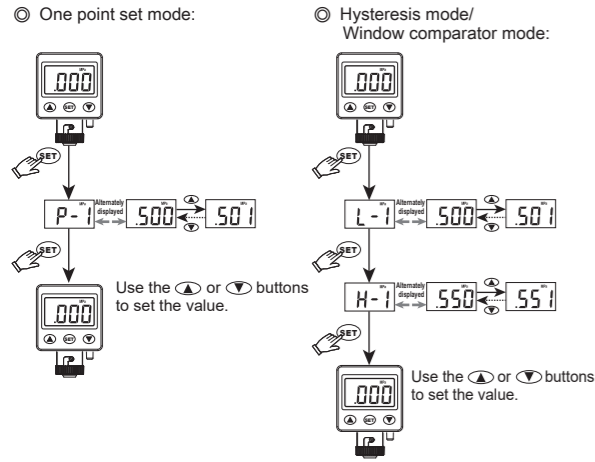

K. OUTPUT TYPE

(1) One point set mode:

Normal open mode

High / Compound / Positive Pressure (PSH-75 / PSC-75 / PSN-75)

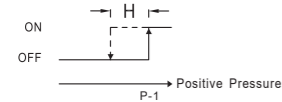

Normal close mode

High / Compound / Positive Pressure (PSH-75 / PSC-75 / PSN-75)

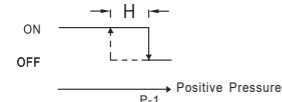

(2) Hysteresis mode:

Normal open mode

High / Compound / Positive Pressure (PSH-75 / PSC-75 / PSN-75)

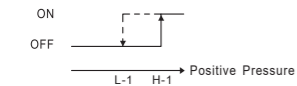

Normal close mode

High / Compound / Positive Pressure (PSH-75 / PSC-75 / PSN-75)

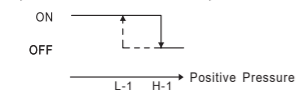

(3) Window comparator mode:

Normal open mode

High / Compound / Positive Pressure (PSH-75 / PSC-75 / PSN-75)

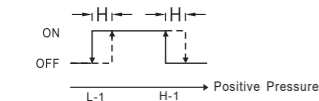

Normal close mode

High / Compound / Positive Pressure (PSH-75 / PSC-75 / PSN-75)

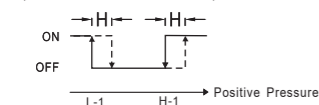

[NOTE:]

*1. In case hysteresis is set at less than or equal to 2 digits, switch output may chatter if input pressure fluctuates near the set point.

*2. When using window comparator mode, the difference between two set points must be greater than the fixed hysteresis, otherwise will cause the switch output to malfunction.

L. COMMUNICATION PROTOCOL (Modbus RTU)

(1) Computer /PLC transmit data format (Master)

ID Number	Read	Function Code	Data Number	CRC CheckSum
1 Byte	1 Byte	2 Byte	2 Byte	2 Byte

(2) Pressure sensor response data format (Slave <PS-75>)

ID Number	Read	Data Number	Data	CRC CheckSum
1 Byte	1 Byte	1 Byte	2N Byte(*)	2 Byte

* N is the number of data

(3) Computer /PLC transmit data format (Master)

ID Number	Write	Function Code	Data	CRC CheckSum
1 Byte	1 Byte	2 Byte	2 Byte	2 Byte

(4) Pressure sensor response data format (Slave <PS-75>)

ID Number	Write	Function Code	Data	CRC CheckSum
1 Byte	1 Byte	2 Byte	2 Byte	2 Byte

(5) Pressure sensor response data format (Error)

ID Number	Write	Error Code	CRC CheckSum
1 Byte	1 Byte	1 Byte	2 Byte

(6) Read / Write Code

Read / Write Code	Description
03H	Read pressure sensor data Range 1~4 data Number, 2~8 Bytes
06H	Write pressure sensor data

(7) Example : Read pressure sensor value Computer /PLC transmit data format (Master)

ID Number (01H)	Read (03H)	Function Code (0002H)	Data Number (0001H)	CRC CheckSum (25CAH)
-----------------	------------	-----------------------	---------------------	----------------------

Pressure sensor data format

ID Number (01H)	Read (03H)	Data Number (02H)	Data (0001H)	CRC CheckSum (7984H)
-----------------	------------	-------------------	--------------	----------------------

(8) Example : ID Number setting response Computer /PLC transmit data format (Master)

ID Number (01H)	Write (06H)	Function Code (0000H)	Data (0001H)	CRC CheckSum (480AH)
-----------------	-------------	-----------------------	--------------	----------------------

Pressure sensor response data

ID Number (01H)	Write (06H)	Function Code (0000H)	Data (0001H)	CRC CheckSum (480AH)
-----------------	-------------	-----------------------	--------------	----------------------

Example : ID Number setting response error

ID Number (01H)	Write (06H)	Function Code (0000H)	Data (01FFH)	CRC CheckSum (C81AH)
-----------------	-------------	-----------------------	--------------	----------------------

Pressure sensor response error (Example : setting data is over)

ID Number (01H)	Write (06H)	Error Code (03H)	CRC CheckSum (0261H)
-----------------	-------------	------------------	----------------------

(When the pressure sensor is abnormal, MSB will be set to 1, so the command code is 86H)

(9) Function Code :

Function Code	Description	Operation
0000H	ID Number (Range:0~255)	Read / Write
0001H	Pressure Type (1:Compound 3:Positive 4:High)	Read
0002H	Pressure Value	Read
0003H	Unit (0:kPa 1:kgf 2:bar 3:psi 4:inHg 5:mmHg 6:MPa)	Read / Write
0004H	Decimal dot (Range:0~3 digit)	Read
0005H	Switch operation mode (0:ops 1:hys 2:win)	Read / Write
0006H	Switch operation type (0:NO 1:NC)	Read / Write
0007H	Response time (0:2.5ms 1:25ms 2:100ms 3:250ms 4:500ms 5:1000ms 6:1500ms)	Read / Write
0008H	Display color select (0:SOG 1:SOR 2:GRN 3:RED)	Read / Write
0009H	Fixed hysteresis value selection (Range : 1~8)	Read / Write
000AH	Power-save mode (0:OFF 1:ON)	Read / Write
000BH	Display fine adjustment mode (Range : -25%~25%) (The actual display is : -2.5%~2.5%)	Read / Write
000CH	Baud rate setting (0:9600 1:19200 2:38400 3:115200)	Read / Write
000DH	Transmission format setting (0:N,8,1 1:E,8,1 2:O,8,1)	Read / Write
000EH	Communications protocol setting (0:RTU / 1:ASC)	Read / Write
000FH	Restore factory setting(write range: 0 or 1)	Write
0010H	Operation point setting ; P-1 or L-1 (Range : According to pressure type and unit)	Read / Write
0011H	Operation point setting ; H-1 (Range : According to pressure type and unit)	Read / Write
0012H	Switch state (0:OFF 1:ON)	Read
0013H	Key lock function (0:OFF 1:ON)	Read / Write
0014H	Switch type (0:NPN 1:PNP)	Read
0015H	Display refresh time setting (0:200ms 1:500ms 2:1000ms 3:1500ms)	Read / Write
0016H	Zero reset (If ambient pressure is over $\pm 3\%$ F.S. , error code shows 03H)	Write

(10) Error Code Description :

Error Code	Description
01H	Read / Write error
02H	Function Code error
03H	Illegal data or over setting value

M. COMMUNICATION PROTOCOL (Modbus ACSII)

(1) Computer /PLC transmit data format (Master)

Head	ID Number	Read	Function Code	Data Number	LRC CheckSum	Trailer CR+LF
1 Byte	2 Byte	2 Byte	4 Byte	4 Byte	2 Byte	2 Byte

(2) Pressure sensor response data format (Slave <PS-75>)

Head	ID Number	Read	Function Code	Data	LRC CheckSum	Trailer CR+LF
1 Byte	2 Byte	2 Byte	2 Byte	4N Byte(*)	2 Byte	2 Byte

* N is the number of data

(3) Computer /PLC transmit data format (Master)

Head	ID Number	Write	Function Code	Data	LRC CheckSum	Trailer CR+LF
1 Byte	2 Byte	2 Byte	4 Byte	4 Byte	2 Byte	2 Byte

(4) Pressure sensor response data format (Slave <PS-75>)

Head	ID Number	Write	Function Code	Data	LRC CheckSum	Trailer CR+LF
1 Byte	2 Byte	2 Byte	4 Byte	4 Byte	2 Byte	2 Byte

(5) Pressure sensor response data format (Error)

Head	ID Number	Write	Error Code	LRC CheckSum	Trailer CR+LF
1 Byte	2 Byte	2 Byte	2 Byte	2 Byte	2 Byte

(6) Read / Write Code

Read / Write Code	Description
30H33H	Read pressure sensor data Range 1~4 data Number, 4~16 Bytes
30H36H	Write pressure sensor data

(7) Example : Read pressure sensor value Computer /PLC transmit data format (Master)

Head (3AH)	ID Number (30H31H)	Read (30H33H)	Function Code (30H30H30H32H)	Data Number (30H30H30H31H)	LRC CheckSum (46H39H)	Trailer (0DH0AH)
------------	--------------------	---------------	------------------------------	----------------------------	-----------------------	------------------

Pressure sensor response data format

Head (3AH)	ID Number (30H31H)	Read (30H33H)	Data Number (30H32H)	Data (30H30H30H31H)	LRC CheckSum (46H39H)	Trailer (0DH0AH)
------------	--------------------	---------------	----------------------	---------------------	-----------------------	------------------

(8) Example : ID Number setting response Computer /PLC transmit data format (Master)

Head (3AH)	ID Number (30H31H)	Write (30H36H)	Function Code (30H30H30H30H)	Data (30H30H30H31H)	LRC CheckSum (46H39H)	Trailer (0DH0AH)
------------	--------------------	----------------	------------------------------	---------------------	-----------------------	------------------

Pressure sensor response data

Head (3AH)	ID Number (30H31H)	Write (30H36H)	Function Code (30H30H30H30H)	Data (30H30H30H31H)	LRC CheckSum (46H39H)	Trailer (0DH0AH)
------------	--------------------	----------------	------------------------------	---------------------	-----------------------	------------------

Example : ID Number setting response error

Head (3AH)	ID Number (30H31H)	Write (30H36H)	Function Code (30H30H30H30H)	Data (30H31H46H46H)	LRC CheckSum (46H39H)	Trailer (0DH0AH)
------------	--------------------	----------------	------------------------------	---------------------	-----------------------	------------------

Pressure sensor response error (Example : setting data is over)

Head (3AH)	ID Number (30H31H)	Write (38H36H)	Error Code (30H33H)	LRC CheckSum (37H36H)	Trailer (0DH0AH)
------------	--------------------	----------------	---------------------	-----------------------	------------------

(When the pressure sensor is abnormal, MSB will be set to 1, so the command code is 38H36H)

(9) Function Code :

Function Code	Description	Operation
30H30H30H30H	ID Number (Range:0~255)	Read / Write
30H30H30H31H	Pressure Type (1:Compound 3:Positive 4:High)	Read
30H30H30H32H	Pressure Value	Read
30H30H30H33H	Unit (0:kPa 1:kgf 2:bar 3:psi 4:inHg 5:mmHg 6:MPa)	Read / Write
30H30H30H34H	Decimal dot(Range:0~3 digit)	Read
30H30H30H35H	Switch operation mode (0:ops 1:hys 2:win)	Read / Write
30H30H30H36H	Switch operation type (0:NO 1:NC)	Read / Write
30H30H30H37H	Response time (0:2.5ms 1:25ms 2:100ms 3:250ms 4:500ms 5:1000ms 6:1500ms)	Read / Write
30H30H30H38H	Display color select (0:SOG 1:SOR 2:GRN 3:RED)	Read / Write
30H30H30H39H	Fixed hysteresis value selection (Range : 1~8)	Read / Write
30H30H30H41H	Power-save mode (0:OFF 1:ON)	Read / Write
30H30H30H42H	Display fine adjustment mode (Range : -25%~25%) (The actual display is : -2.5%~2.5%)	Read / Write
30H30H30H43H	Baud rate setting (0:9600 1:19200 2:38400 3:115200)	Read / Write
30H30H30H44H	Transmission format setting (0:N,8,1 1:E,8,1 2:O,8,1)	Read / Write
30H30H30H45H	Communications protocol setting (0:RTU / 1:ASC)	Read / Write
30H30H30H46H	Restore factory setting(write range: 0 or 1)	Write
30H30H31H30H	Operation point setting ; P-1 or L-1 (Range : According to pressure type and unit)	Read / Write
30H30H31H31H	Operation point setting ; H-1 (Range : According to pressure type and unit)	Read / Write
30H30H31H32H	Switch state (0:OFF 1:ON)	Read
30H30H31H33H	Key lock function (0:OFF 1:ON)	Read / Write
30H30H31H34H	Switch type (0:NPN 1:PNP)	Read
30H30H31H35H	Display refresh time setting (0:200ms 1:500ms 2:1000ms 3:1500ms)	Read / Write
30H30H31H36H	Zero reset (If ambient pressure is over $\pm 3\%$ F.S. , error code shows 30H33H)	Write

(10) Error Code Description :

Error Code	Description
30H31H	Read / Write error
30H32H	Function Code error
30H33H	Illegal data or over setting value

N. ZERO POINT SETTING

Press the Δ + ∇ buttons at the same time until the "00" is shown, release the button to end zero setting.

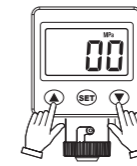

O. THE MAX. & MIN. DISPLAY MODE

●The Max. value display mode: ●The Min. value display mode:

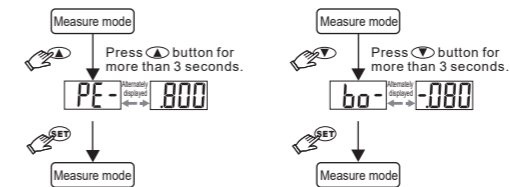

P. KEY LOCK/UNLOCK MODE

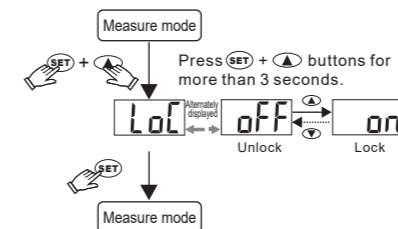

● Under key lock mode, it displays as figure below when pressing any key. After some time, it would be returned to measure mode.



Q. FINE ADJUSTMENT MODE

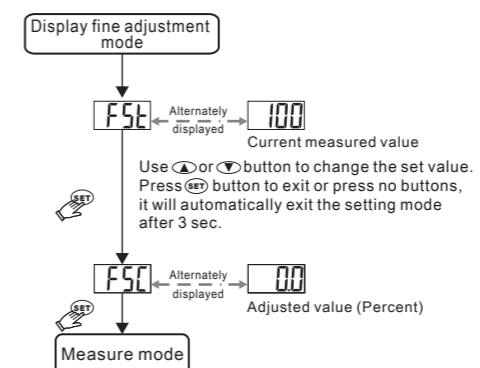

This function eliminates slight differences in the output values and allows uniformity in the numbers displayed. Displayed values of the pressure sensor can be calibrated to within $\pm 2.5\%$ R.D.

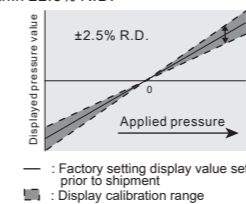

R.D. (Real Detect)
 【NOTE:】 1. Setting resolution is $\pm 0.1\%$ R.D.
 2. The signal would be changed with analog output after adjusting.

R. REMOVABLE SNUBBER INSTALLED

Pressure port equipped with snubber can avoid damage caused by sudden pressure surge of water or oil, improve product durability.

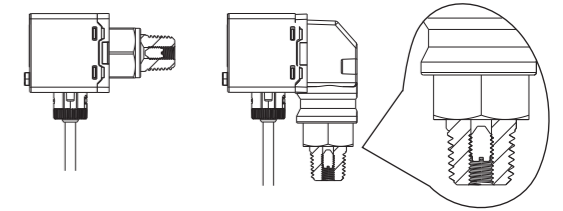

*When snubber is clogged with contaminants, please use a flat head screwdriver to remove the snubber, clean and reinstall.

S. PRESSURE UNIT CONVERSION TABLE

From	To	Pa	kPa	MPa	kgf/cm ²	psi	bar	inHg
1 Pa	1	0.001	0.000001	0.000010197	0.000145038	0.0001	0.0002953	
1 kPa	1000.000	1	0.001000	0.010197	0.145038	0.010000	0.2953	
1 MPa	1000000	1000	1	10.197	145.038	10	295.2998	
1 kgf/cm ²	98066.5	98.0665	0.0980665	1	14.2233	0.980665	28.9579	
1 psi	6895	6.895	0.006895	0.07031	1	0.06895	2.036074	
1 bar	100000.0	100.0000	0.100000	1.01972	14.5038	1	29.52998	
1 inHg	3386.388	3.386388	0.003388	0.034530	0.491141	0.033863	1	

T. WIRE INSTALLATION INSTRUCTION

Please install the wire as the following step.

- Locate the salient point on the terminal. (See figure ①)
- Align the salient point to the groove on the pressure sensor to insert. (See figure ②)
- Align the index point to the groove install the terminal cover. (See figure ③)
- Turn the terminal cover clockwise to lock. (See figure ④)

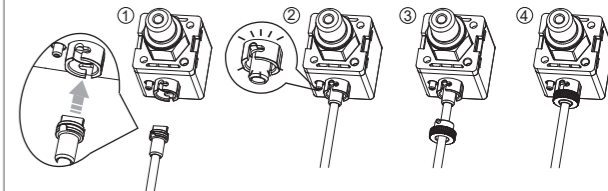

【NOTE:】 Recommend not to insert-extract over 20 times.