

# HDM2 series – 180° Angular gripper

Internal structure, Components and material list,  
Product weight, Packing and O-ring part list

**CHELIC**

## Internal structure

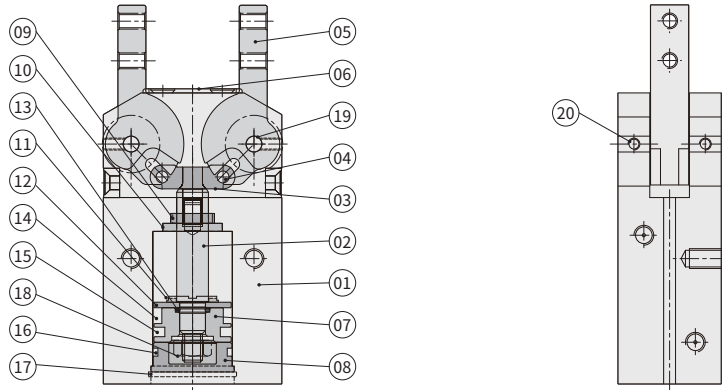

## Components and Material list

No.	Item	Material	No.	Item	Material
01	Body	Aluminum alloy	11	Cushion gasket	NBR
02	Shaft	Stainless steel	12	Magnet cap	Copper alloy
03	Finger connector	Alloy steel	13	Shaft O-ring	NBR
04	Needle roller	Bearing steel	14	Rare earth magnet	Rare earth metal
05	Finger	Stainless steel	15	Piston packing	NBR
06	Dust cover	Stainless steel	16	Rear cover O-ring	NBR
07	Piston	Copper alloy	17	C clip	Spring steel
08	Rear cover	Aluminum alloy	18	Locknut	Alloy steel
09	Shaft packing	NBR	19	Pin	Bearing steel
10	Packing plate	Copper alloy	20	Plug	Alloy steel

## Packing and O-ring part list

Item	Piston packing	Shaft packing	Rear cover O-ring
Model \ Quantity	1	1	1
HDM2 Ø12	APA-12	MYA-5	Ø10 X Ø1.0
HDM2 Ø16	APA-16	MYA-6	Ø13.2 X Ø1.5
HDM2 Ø20	APA-20	MYA-8	Ø17.5 X Ø1.5
HDM2 Ø25	APA-25	MYA-10	Ø22 X Ø1.5
HDM2 Ø32	APA-32	MYA-12	Ø28.5 X Ø2.0

The piston packing and shaft packing are from MITSUBISHI, SAKAGAMI or the same good level of quality material

## Product weight

Model	Weight(kg)
HDM2 Ø12	0.1
HDM2 Ø16	0.16
HDM2 Ø20	0.52
HDM2 Ø25	0.72
HDM2 Ø32	1.18

Note: All the above are theoretical data; weight deviation is approximately ±5%.